

# **CAM-OPERATED MECHANICAL RECORDING TEMPERATURE PROGRAMMER**

The RFC52 is a single switch, cam-operated recording temperature programmer. The instrument incorporates an internally-mounted three wire thermostatic relay to provide indefinite switch life and higher electrical switching capabilities. It derives its simplicity and efficiency from the Piston-Pak filled systems sensing element.

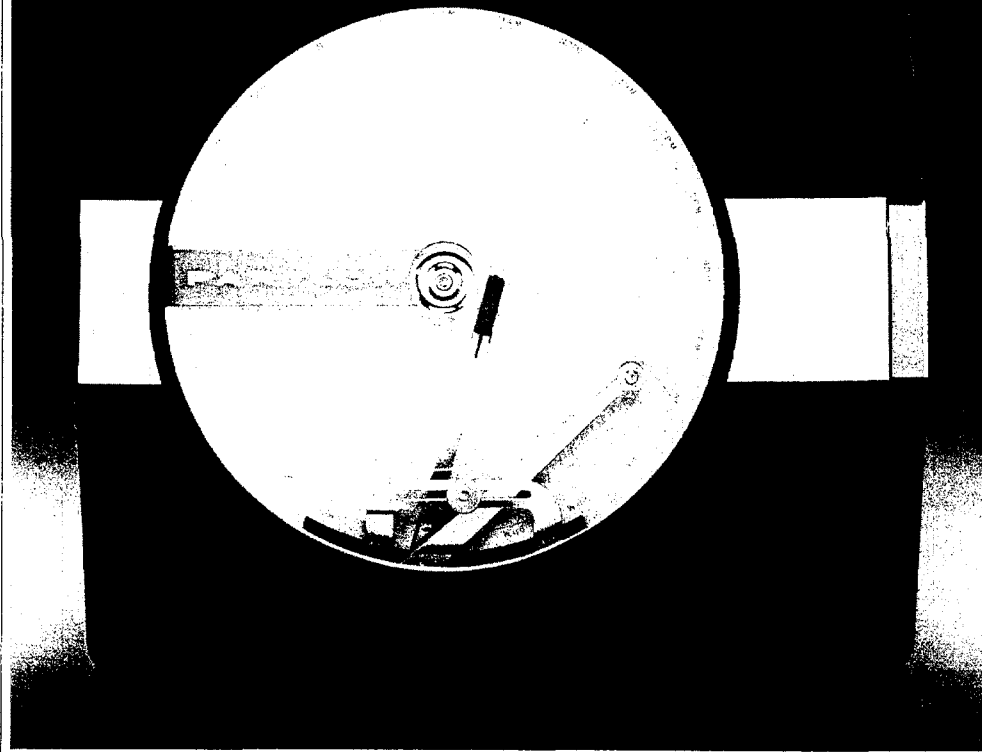

Form Number 3231  
Pub. August 1991  
First Edition

**SPECIFICATIONS  
INSTALLATION  
OPERATION**

# RFC52

**Partlow**

The Partlow Corporation • Two Campion Rd. • New Hartford, NY 13413 USA • 315-797-2222 • FAX 315-797-0403  
**QUALITY INSTRUMENTATION DESIGNED & MANUFACTURED IN THE USA**

## Dynapar, Veeder Root, and Eagle Signal Brands:

Sales, Repair, and Application Support:  
1675 Delany Rd.  
Gurnee, IL. 60031  
847-662-4150 Sales/Order Entry Fax  
847-782-5277 Applications Support Fax  
800-873-8731 Sales/Order Entry  
800-234-8731 Applications Support

## NorthStar Brand:

Sales, Repair, and Application Support:  
1675 Delany Rd.  
Gurnee, IL. 60031  
847-782-5288 Sales/Order Entry Fax  
847-782-5277 Applications Support Fax  
800-326-6216 Sales/Order Entry  
800-326-6216 Applications Support

## Partlow, West, Rustrak, and LFE Brands:

Sales, Repair, and Application Support:  
1675 Delany Rd.  
Gurnee, IL. 60031  
847-662-4150 Sales/Order Entry Fax  
847-782-5277 Applications Support Fax  
800-873-8731 Sales/Order Entry  
800-866-6659 Applications Support

Please disregard all phone numbers and addresses in this manual. The phone numbers and address on this page are the correct phone number and addresses to use for sales, repair, and application support.

## RFC52 PRODUCT SPECIFICATIONS

Dimensions	15 1/8"W X 13 13/16"H X 4 7/8"D
Surface Mounting	Brackets included
Flush Mount Cutout	13 1/2"W X 12 11/16"H
Chart Diameter	10 inch
Chart Marking	Felt Tip Cartridge
Chart Drive	Electric with toggle switch
Chart Rotation Periods	24 hour, 7 day
Conduit Openings	One 7/8 inch diameter hole on each side of the case for 1/2 inch conduit fitting; drill guide hole spotted in the rear of the case showing optional rear conduit location.
Switch Specifications	Partlow #52 super sensitive (1/2% of element range). Switch controls a 3-wire thermostatic relay for actual handling of electric load.
Electrical Rating	6 amps at 125VAC, 3 amps at 250VAC inductive or non-inductive load (through 2 pole thermostatic relay contacts).
Rated Accuracy	1% of element range.
Agency Approval	Canadian Standards Association
Approx. Net Weight*	9 lbs
Approx. Shipping Weight*	14 lbs

\* Weight may vary depending on element length.

**Note:**  
*It is strongly recommended that Partlow equipped applications incorporate a high or low limit protective device which will shut down the equipment at a preset temperature condition in order to preclude possible damage to property or product.*

*This document should accompany the instrument to its final installation in order to provide operational and service assistance to the end user.*

## RFC52 ORDER MATRIX

	<b>R</b>	<b>F</b>	<b>0</b>	<b>9</b>			
<b>RFC52</b> (Requires L-type Element Plunger)							
<b>CHART DRIVES*</b>							
125V/60Hz      24 H      01							
125V/60Hz      7 D      02							
250V/50Hz      24 H      03							
250V/50Hz      7 D      04							
250V/60Hz      24 H      05							
<b>ACCESSORIES</b>							
0      None							
2      250P Cam Follower Attachment							

\* Price includes 100 ink type charts and blank cam.

### PISTON-PAK THERMAL SENSING ELEMENT

A Piston-Pak Thermal Sensing Element must be specified for each RFC52. Use Partlow Form 3028 "Mechanical Instrumentation Products Cross Reference and Pricing Guide" to configure the matrix number for the sensing element.

# INSTALLATION

## LOCATION

The element head assembly is subject to ambient temperature limitations of -30°F to 125°F (-35°C to 52°C) for low temperature head assemblies, and 32°F to 150°F (0°C to 66°C) for high temperature head assemblies. These temperature limitations must be considered when determining the instruments location. It should be located in an area as free from vibration as possible.

## MOUNTING

The instrument(s) are shipped to be surface mounted. Figure 1 illustrates hole placement for surface mount condition.

Note: Holes in brackets supplied are 9/32 clearance holes for 1/4" bolts. The four holes called out in the drawing may be any size that will accommodate the fastening requirement, ie: 9/32 for 1/4" thru-bolt with nut fastening, or #7 drill for 1/4" x 20 NC tapped hole fastening or #3 drill for 1/4" x 28 NF tapped hole fastening.

The instrument may also be flush mounted. This is accomplished by removing the two surface mounting angle brackets from the instrument. Figure 1A illustrates panel cut out dimensions. Cut the panel opening to 13 1/2" x 12 5/8". Drill 9/32 clearance holes in four locations if 1/4" thru-bolt with nut installation is desired. Should a tapped hole be preferable, drill a #7 hole in four locations for 1/4" x 20 NC or a #3 hole in four locations for a 1/4" 28 NF. **Note: All configurations require a flat head screw for proper door operation. With the instrument in the upright position, insert it and the element with the panel opening and tilt into place.**

Depending upon your panel size it may be easier to make electrical connections before finally securing the instrument into the panel.

## WIRING

Check applicable electrical codes, ordinances and regulations regarding use of conduit, etc. **If acceptable, make connection using short sections of flexible cable or conduit.**

The rear conduit hole should be used for panel mount installations. A drill guide hole is spotted in the back of the case to accommodate field drilling (see Dimensional Drawing on Page 7) Refer to the wiring diagram in Figure 2 and proceed. Open the instrument's hinged cover and remove the insulator covering connection terminal block. Note: the terminals are designated 1, 2, H, C, L. Ground is located above the top cover of the terminal block designated by the green ground screw. Connect specified power to terminals 1 and 2 (chart drive terminals). Make necessary connections to H, C, L terminals according to Figure 2 (page 4). Re-install insulator over terminal block.

Figure 1 - Surface Mount Dimensions

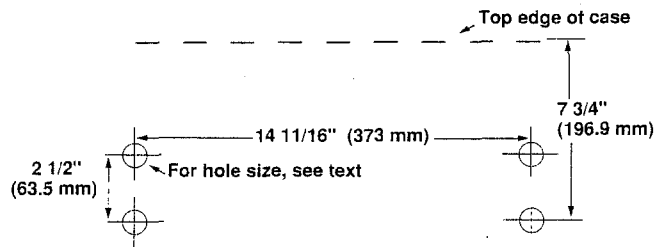

Figure 1A - Panel Cutout Illustration (in inches)

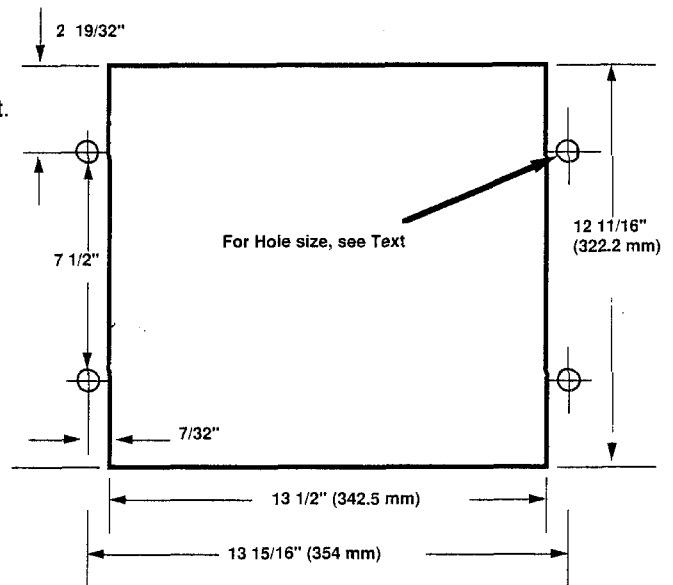
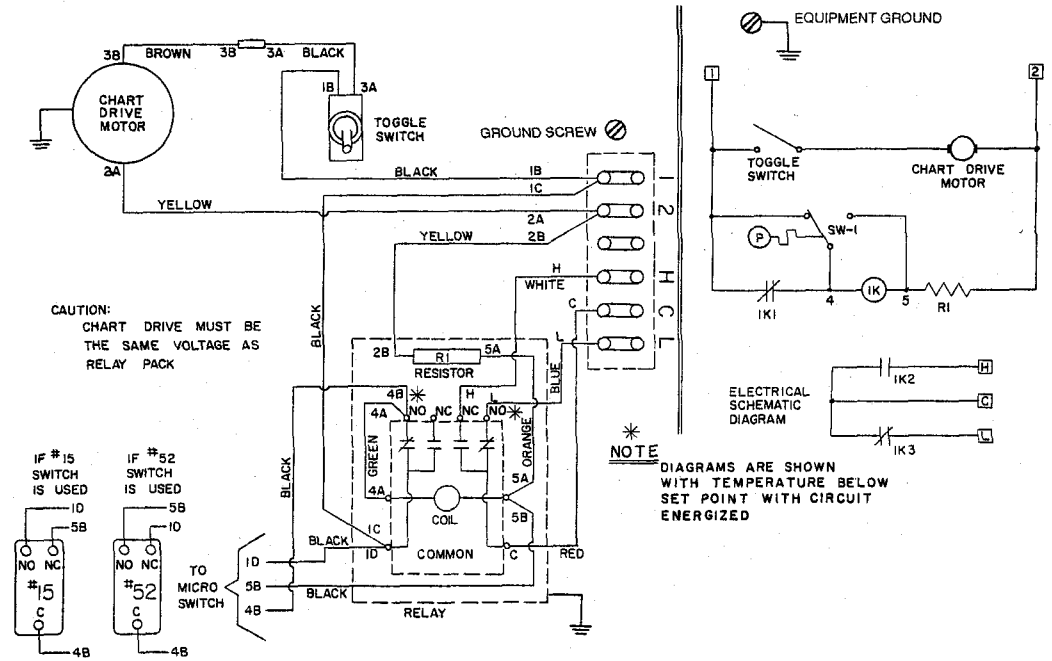

Figure 2 - Wiring Connections

CONNECTIONS



**PLACING THE THERMAL SENSING ELEMENT**

Locate the thermal sensing bulb in the most agitated part of the medium to be measured and completely immerse it. (When U and Y type bulbs are used, note separation coupling between bulb and capillary). Be sure to immerse the element up to the coupling for correct temperature indication. Do not bend capillary to less than 1/2 inch radius and never bend it too close to the element bulb or element head. Pencil type bulbs must never be bent as this will affect instrument accuracy. U and Y-type bulbs may be bent but never to less than a two inch radius. Anchor the excess capillary securely to prevent vibration damage. These bulbs may be elevated up to 40 feet above the instrument without affecting calibration. For elevations over 40 feet consult with your local Partlow Representative, Distributor or the Factory.

**STUFFING BOX INSTALLATION (IF APPLICABLE)**

Overtightening of 21-T-105 steel or stainless steel stuffing boxes can damage the thermal element by restricting the capillary bore. To prevent damage, the stuffing box gland nut should be turned 1/2 to 3/4 of a revolution from a finger tight position. This is equivalent to a torque of 65 to 100 inch-pounds for steel and 130 to 180 inch-pounds for stainless steel.

## INSTRUMENT OPERATION

Prior to putting the instrument into service, check it against an accurate test thermometer. As with any precision instrument minor adjustments may be necessary after shipment and installation. If you are unfamiliar with how to perform this check refer to the CHECKING TEMPERATURE and RE-ZEROING section of this document, below.

Control temperature point on the RFC52 is determined by a cam follower which rides the edge of a revolving pre-cut cam and positions the snap-acting switch in accordance with the program for which the cam is shaped. The three-wire single-pole double-throw switch is actuated by the same temperature responsive mechanism that moves the recording pen and is factory-set to actuate when the pen is in alignment with the center-line of the cam-follower. The switch, in turn, operates the three-wire thermostatic relay which handles the electrical load.

When installing or resetting a program cam or chart, be sure edge of cam fits into groove of cam-follower. Check to be certain that printing on cam faces **outward** when installed, and gently bring follower against cam. **Do not allow follower to snap back against cam or chart hub.** A catch is provided just outside chart edge to hold follower out of the way when changing cam and/or chart. A Hub Holder and Hex Socket Key (see Figure 3, at right) are provided to tighten and loosen chart hub.

**Caution: When tightening or loosening Cam Clamp Screw, hold Cam Hub firmly in position with Hub Holder Tool and turn Cam Clamp Screw using Hex Socket Key.**

Figure 3 - Hub Holder and Hex Socket Key

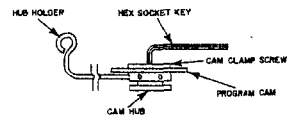

## MAINTENANCE

### CHECKING TEMPERATURE

When checking and verifying your temperature be sure to use a test thermometer of known accuracy. Position the test thermometer sensing bulb or probe adjacent to the thermal sensing bulb from the RFC52. Turn the red set pointer to the desired process temperature. Wait for the temperature to stabilize, then compare the test thermometer reading with that of the RFA. If the two readings do not agree, the RFC52 should be re-zeroed.

### RE-ZEROING

Be sure that the process temperature is stable. Note the amount of temperature difference between the test thermometer reading and the pen indicated temperature. Open instrument cover and loosen the set screw S (Figure 4, at right). Zeroing is accomplished by turning hex shaft J with the wrench provided. Lengthening shaft J (counterclockwise) raises pen indicated temperature, shortening shaft J (clockwise) lowers pen reading. Position the red set pointer to the high end of the chart and shut off power to the instrument. Then turn shaft J accordingly and correct the pen reading the **same number of degrees as was found to be the difference between the temperature indicated by the test thermometer and the instrument.** Re-tighten set screw S. Return the red set pointer to its original setting and restore power. Check the adjustment by allowing the temperature to stabilize and compare the readings. Repeat these steps if necessary.

**Note: Power shut down described above prevents process temperature from building while adjustments are being made. If, however, the situation exists where power shutdown is not feasible, follow the same procedures but make shaft J adjustments as quickly as possible. In systems where temperature builds very rapidly, zeroing procedures may have to be repeated several times.**

Figure 4 - Re-Zeroing

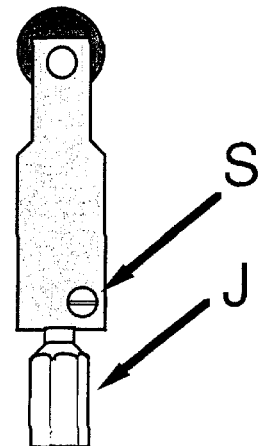

**SWITCH REPLACEMENT**

See Figure 5 for more detail.

Turn the power off to the instrument. Remove cam, chart and platen (see Exploded View Illustration on Page 11). Remove the two screws holding switch in switch arm. Take faulty switch out of switch arm. Remove screws that fasten wires on the switches. **Note: Remove wires separately and transfer each separately to new switch.** Re-assemble new switch back in holding arm. Re-install chart and cam and re-supply power.

**Note: Switch replacement may slightly alter switch actuation point. Adjustment to switch actuation screw E may be necessary. See Figure 5.**

After switch has been replaced and temperature has been allowed to stabilize (using constant temperature section of cam), check to see if pen-indicated temperature on the chart agrees with the known setpoint temperature on the cam. If the two temperatures do not agree, adjust switch adjusting screw E accordingly until pen-line temperature and cam temperature are in agreement. **Be sure to allow temperature to stabilize after each screw E adjustment.**

**RELAY PACK REPLACEMENT**

Disconnect power from the instrument. Remove cam, chart and platen. Remove the two screws holding the switch in the switch arm. Remove wires from terminal block that go to the relay pack. Be certain to note wiring sequence. Remove screws that secure relay pack into place. Remove assembly completely (Note: switch is still attached to relay pack) using replaced assembly as a guide. Install new switch in mechanism assembly and wire to new relay pack. Install replacement relay pack into instrument. Attach replacement relay pack into instrument. Attach wires to terminal block accordingly (see Figure 2 for detail). Re-attach replaced switch into switch arm. Apply power to test wiring. Actuate mechanism switch. Relay should toggle. If not, check Figure 2 for correct hookup. Should relay perform correctly, re-attach platen to instrument. Refer to paragraph 2 in SWITCH REPLACEMENT section for switch adjustment.

**PISTON-PAK THERMAL SENSING ELEMENT IDENTIFICATION**

An element designation number is stamped on the bottom of the element head. This is a coded description of the element specifications and should be used whenever a replacement element is ordered. The number appearing on the side of the element head (Figure 6, below) is the element age code, which may be required in establishing warranty.

**ORDERING SPECIFYING THE PISTON-PAK SENSING ELEMENT**

The sensing element is ordered separately from the RFC52 and requires its own matrix number. To determine the correct sensing element configuration for your instrument(s) and application, see Partlow Form 3028 "Mechanical Instrumentation Products Cross Reference and Pricing Guide."

Figure 5 -  
Switch Replacement

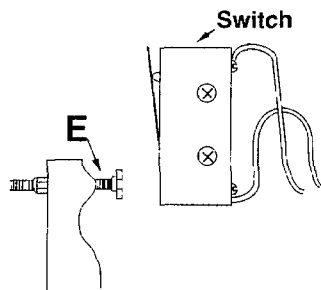
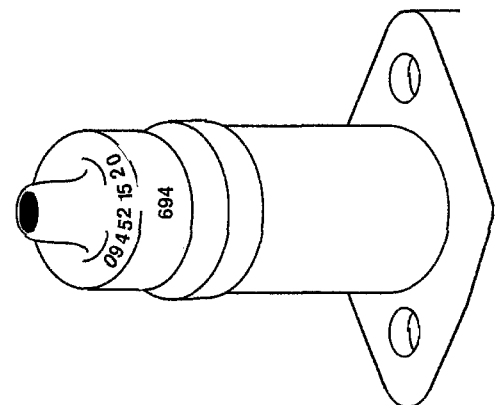

Figure 6 - Sensing Element ID



## ELEMENT REPLACEMENT

To change a thermal sensing element, start by removing screws D (Figure 7, below) and withdrawing the element from the instrument body. Then remove the element bulb from the medium. Install the new element and replace screws D. Insert the new element bulb into the medium being measured.

*Note: After the element has been replaced, check the temperature setting, re-zeroing may be necessary. If so, see the CHECKING TEMPERATURE section (page 5).*

**Caution: The inside mechanism(s), particularly the inside of the element housing, should never be oiled. However, if the instrument is subject to corrosion or gunking conditions, the mechanical linkage should be sprayed periodically with corrosion inhibiting CRC-26, 3-36, or 5-56. Use only CRC2-26, 3-36, or 5-56 as other lubricants may cause build up and sticking of internal parts. Also note that the latch handle assembly should never be lubricated with any chemical. On plastic type door housings the latch may be lubricated using graphite. On aluminum die cast type door housings, the latch may be lubricated using the same lubricant used on the mechanism. CRC2-26 may be purchased from Partlow in a 15 oz. container (part #63600401). CRC5-56 may be purchased locally from any hardware or automotive store.**

Figure 7 - Replacing Element

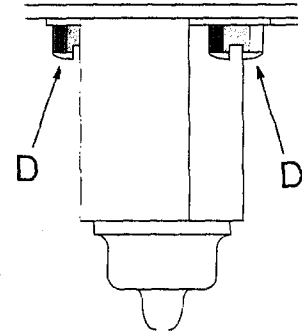

## PLOTTING AND CUTTING CAMS

### PLOTTING TIME-TEMPERATURE CYCLE

Partlow accessory 250P Cam Follower Setting Attachment may be used as an aid in plotting compensated time-temperature cycles. If using accessory 250P, attach the setting bar as described in the instructions accompanying the accessory and proceed as follows:

1. On one of the charts supplied, position the cam-follower at the temperature desired (use template) and tighten the set screw on the stop bar of the setting attachment to hold the cam-follower in the selected position. For all positioning, use template.
2. Start process. After allowing sufficient time for temperature to settle out at set-point, note the differential between setting of the cam-follower and actual temperature recorded.
3. Adjust position of the cam-follower up or downscale until pen records desired temperature, using the template to determine fine adjustments. Be sure that temperature has fully settled out before accepting final adjustment.
4. Repeat this procedure for each additional setting to be plotted on the time-temperature cycle. These compensated figures can then be applied to the cam-cutting procedure which follows.

(Continued on next page)

---

**CUTTING CAMS**

Blank cams are transparent plastic discs 10" in diameter and .080" +/- .012" thick with 1/2" center hole. Procedure for cutting cams is simple but all plotting and cutting must be precisely executed to insure desired time-temperature program.

1. On one of the paper charts supplied, lay out the time-temperature program by plotting on the chart the different temperatures at the time intervals required ( Figure 8 is for illustrative purposes only and does not represent any actual heat process). The maximum rate of rise template (Figure 9) should be used to check cam curve to be sure it falls within the maximum permitted by the control mechanism. The template can also be used to trace maximum rate of temperature rise. Temperature should rise at a rate no greater than the heat input will normally provide. In other words, do not layout a rise rate of, say 100° in 15 minutes unless the normal heat input will raise the temperature that rapidly.
2. Connect the plotted time-temperature points by a smooth curve, A.
3. On curve A, draw a series of connecting 3/8" circles, B centered on the curve.
4. Draw line C tangent to all these circles, on the inner side. Be sure to continue curve C completely around the circle of white space on the chart to the starting point, as shown by the dotted line on the illustration.
5. Remove knurled nut and spacer from the clock shaft and lay back the hinged spacer holder. Place the prepared chart face up on the raised hub of the chart drive flange. Spot a few drops of rubber cement on unmarked areas of the chart and press cam blank firmly on the same hub. After allowing a few minutes for the cement to harden, remove the joined chart and cam blank.
6. Lay the blank and chart on a smooth surface and very carefully trace curve C onto the plastic with a sharp scribe. Then trace a convenient hour line from the chart and inscribe identifying characters next to it; this line will align a recording the recording chart and cam in proper register each time a new chart is placed on the instrument.
7. Peel the chart from the cam blank and carefully cut the cam to the curve scribed from line C, using a band or jig saw, and finish off with a file, making sure outline is 90° to the cam face.

Figure 8 - Plotting Chart

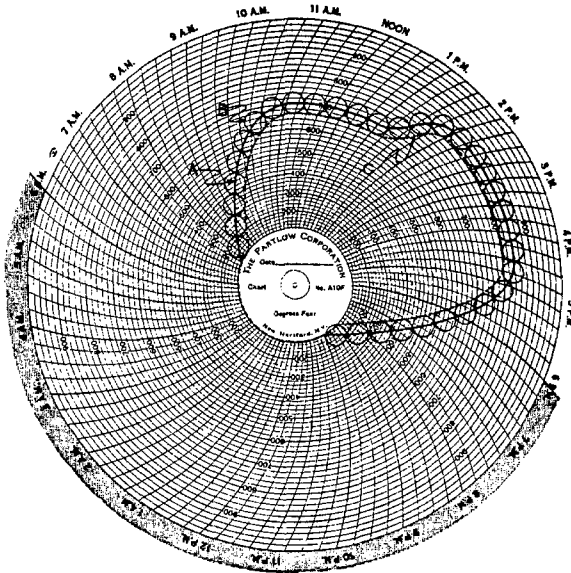
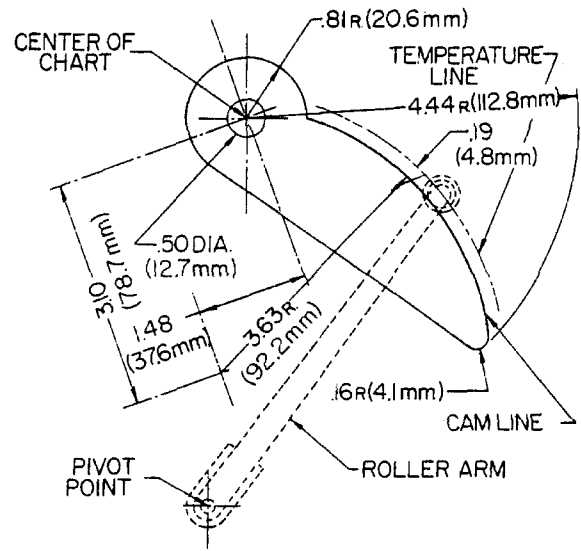

Figure 9 - Maximum rate of rise Template



Maximum Rate of Rise for Temperature and Cam

# DIMENSIONAL DRAWING

Figure 10 - Dimensional Drawing

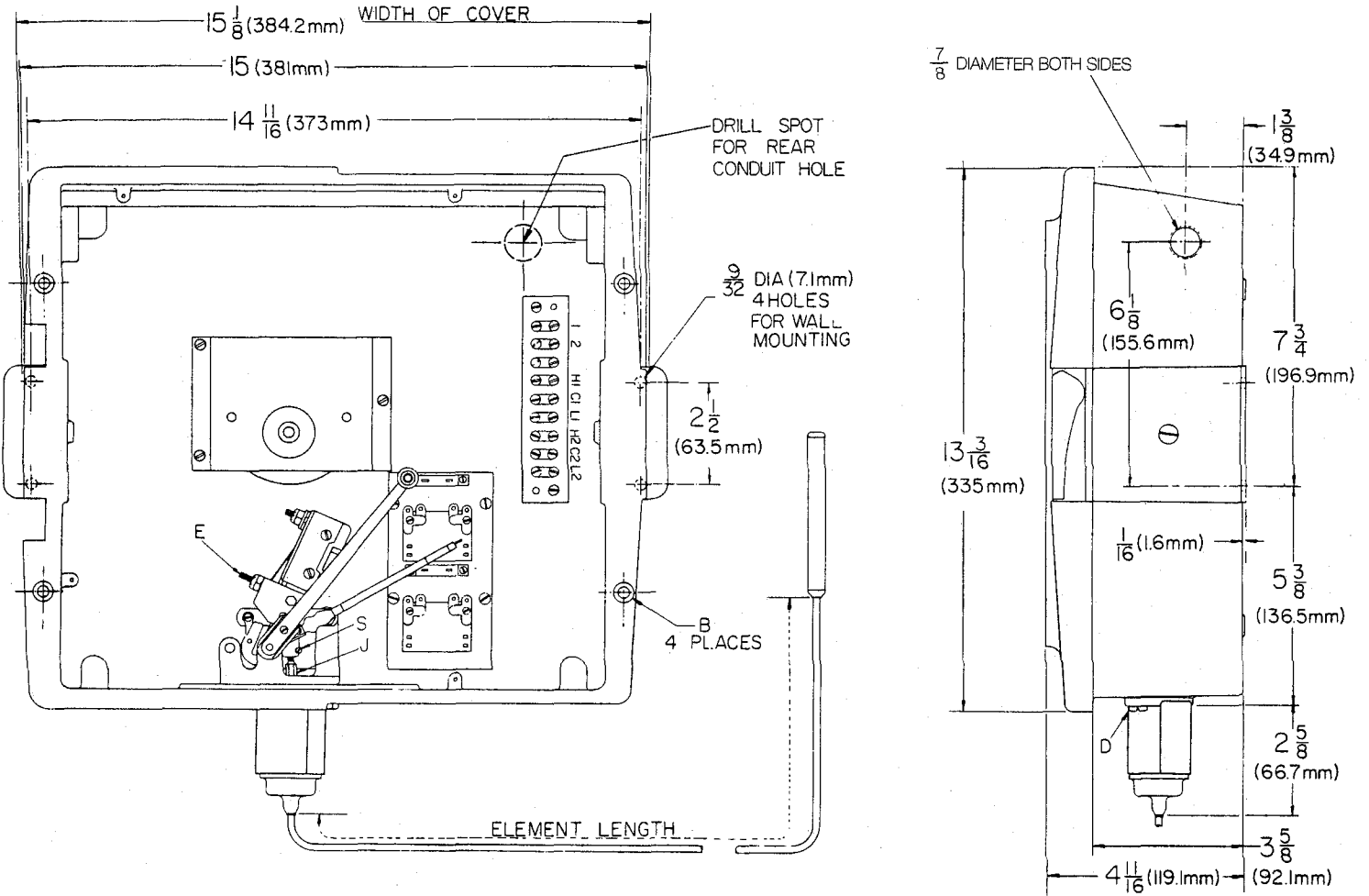
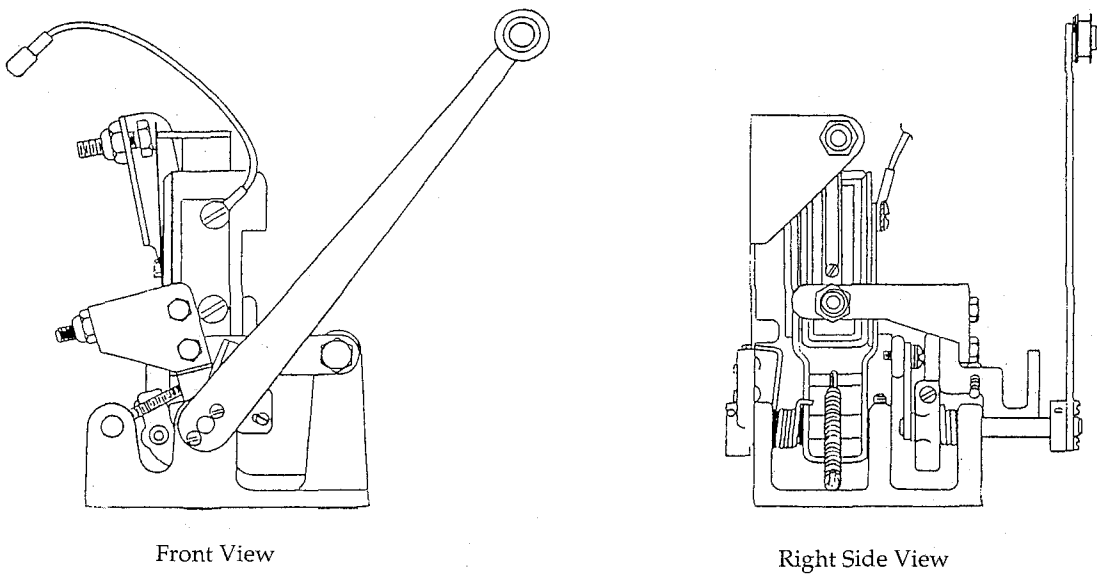

Figure 11 - Mechanism Drawing



# EXPLODED ILLUSTRATION AND PARTS LIST

**1. Case Assembly**

Includes: Case, Ground Plane, Latch Bracket, Mounting brackets with screws, hinge pins and plates, hub strip hinge.

**2. Cover Assembly**

Includes: Cover glass, Gauge glass, glass retaining ring, gaskets, latch handle assembly.

**3. Mechanism Assembly**

Includes: #52 switch, pen, cartridge, and push rod

**3A.\* Relay Pack Assembly**

125 VAC  
250 VAC

\*Replace switch when replacing Relay Pack assembly

**4. Main Lever Assembly**

Includes: Main lever with push rod cap, push rod, setscrew.

**5. Switch Kit**

Includes: #52 Switch

**6. Pen Arm Kit**

Includes: Arm Cartridge and Screws

Cartridge - red, in multiples of 5

**7. Terminal Block Kit**

Includes: Terminal Block, Insulator, Miscellaneous Hardware

For 6 Positions  
For 9 Positions  
For 12 Positions  
For 14 Positions

64415101

SP50007603

10069202

SPRFCSS4  
SPRFCSS4A

64414801

64403012

64402204

60500403

64415002

64415003

64415004

64415005

**8. Chart Nut and Flange Kit**

Includes: Hub nut, Cam clamp and washers and Flange Assembly.

**9. Chart Hub Namestrip**

**10. Platen Assembly**

For Spring Wound or Electric Drives, Stand or Platen mounted.

**11. Chart Drive**

Contact factory for re-order. Specify time base, voltage, and cycle.

**12. Chart Drive Mounting Stand**

Includes: All fasteners and Clamp Plate.

For All Electric Stand Mounted

**13. Blank Cam**

**14. Hardware Kit (not shown)**

Includes: All Body Fasteners (may include fasteners not required for specific models)

64415203

RFCS2

SP10067701

64415601

RFCS9

64415701

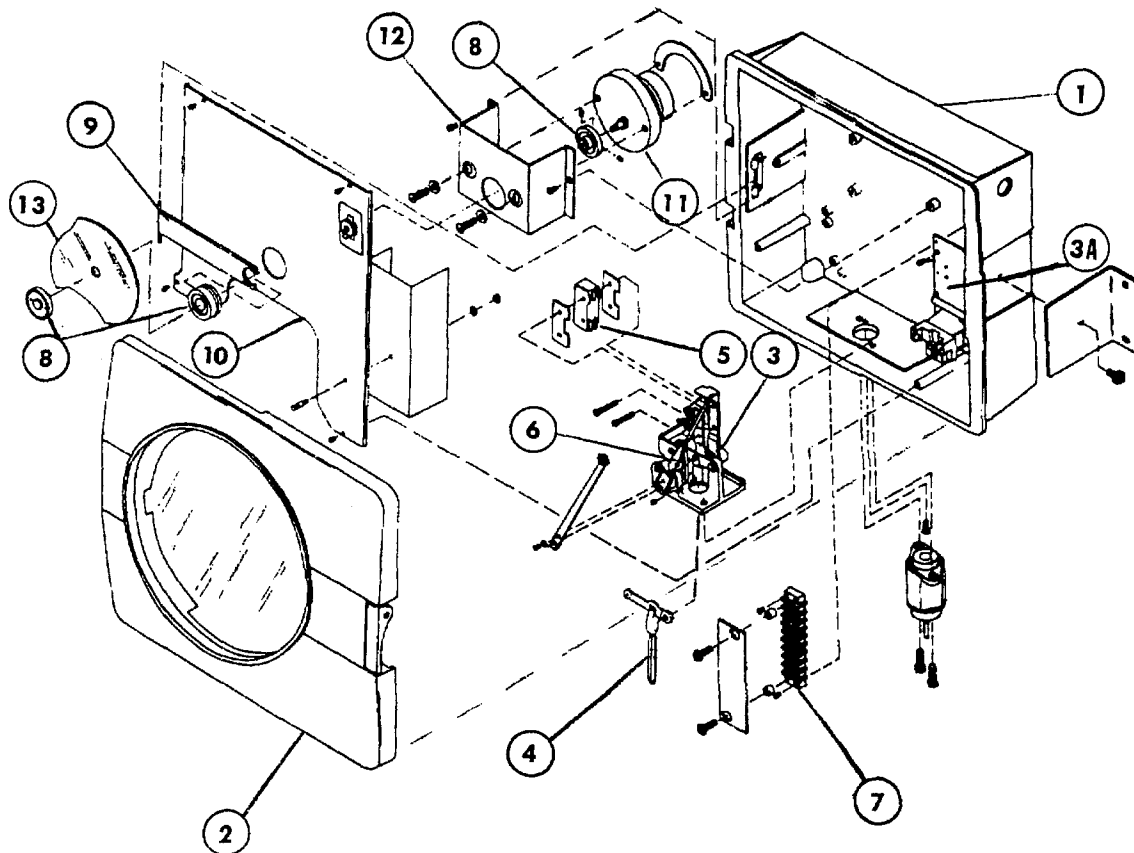

---

# Warranty

These products are sold by The Partlow Corporation ("Partlow") under the warranties set forth in the following paragraph. Such warranties are extended only with respect to a purchase of these products, as new merchandise, directly from Partlow or from a Partlow distributor, representative or reseller, and are extended only to the first buyer thereof who purchases them other than for the purpose of resale.

These products are warranted to be free from functional defects in materials and workmanship at the time the products leave the Partlow factory, and to conform at that same time to the specifications set forth in the relevant Partlow instrumentation sheet, sheets, manual or manuals for such products.

Partlow's sole and exclusive obligation and buyer's sole and exclusive remedy under the above warranties is limited to repairing or replacing, at Partlow's option free of charge, the products which are reported in writing to Partlow at its main office - The Partlow Corporation, 2 Campion Road, New Hartford, New York 13413 or FAX MAIL 1-315-797-0403 and which if so advised by Partlow, are returned with a statement of the observed deficiency to the designated facility during normal business hours, transportation charges prepaid and which upon examination by Partlow are found not to comply with the above warranties. PARTLOW SHALL NOT BE LIABLE FOR ANY INCIDENTAL DAMAGES, CONSEQUENTIAL DAMAGES, SPECIAL DAMAGES, OR ANY OTHER DAMAGES, COSTS OR EXPENSES, EXCEPTING ONLY THE COST OR EXPENSE OF REPAIR OR REPLACEMENT AS ABOVE DESCRIBED.

THERE ARE NO EXPRESSED OR IMPLIED WARRANTIES WHICH EXTEND BEYOND THE WARRANTIES HEREIN ABOVE SET FORTH. PARTLOW MAKES NO WARRANTY OR MERCHANTABILITY OR FITNESS FOR A PARTICULAR PURPOSE WITH RESPECT TO THE PRODUCTS.



---

**Form Number 3231  
Pub. August 1991  
First Edition**

Represented/Distributed By: