

MECHANICAL RECORDING PNEUMATIC TEMPERATURE CONTROLLER

This recording pneumatic temperature controller operates air-powered throttling valves regulating the flow of steam, water or gas. It is also capable of actuating other pneumatic devices such as pressure switches and relays. The RFA derives its simplicity and efficiency from the Piston-Pak filled systems sensing element.



Form Number 3169
Pub. March 1991
First Edition

**SPECIFICATIONS
INSTALLATION
OPERATION**

RFA

Partlow

The Partlow Corporation • Two Campion Rd. • New Hartford, NY 13413 USA • 315-797-2222 • FAX 315-797-0403
QUALITY INSTRUMENTATION DESIGNED & MANUFACTURED IN THE USA

Dynapar, Veeder Root, and Eagle Signal Brands:

Sales, Repair, and Application Support:
1675 Delany Rd.
Gurnee, IL. 60031
847-662-4150 Sales/Order Entry Fax
847-782-5277 Applications Support Fax
800-873-8731 Sales/Order Entry
800-234-8731 Applications Support

NorthStar Brand:

Sales, Repair, and Application Support:
1675 Delany Rd.
Gurnee, IL. 60031
847-782-5288 Sales/Order Entry Fax
847-782-5277 Applications Support Fax
800-326-6216 Sales/Order Entry
800-326-6216 Applications Support

Partlow, West, Rustrak, and LFE Brands:

Sales, Repair, and Application Support:
1675 Delany Rd.
Gurnee, IL. 60031
847-662-4150 Sales/Order Entry Fax
847-782-5277 Applications Support Fax
800-873-8731 Sales/Order Entry
800-866-6659 Applications Support

Please disregard all phone numbers and addresses in this manual. The phone numbers and address on this page are the correct phone number and addresses to use for sales, repair, and application support.

RFA PRODUCT SPECIFICATIONS

Dimensions	15 1/8"W X 13 13/16"H X 4 7/8"D
Surface Mounting	Brackets included
Flush Mount Cutout	13 1/2" W X 12 11/16"H
Chart Diameter	10 inch
Chart Marking	Felt Tip Cartridge
Chart Drive	Electric with toggle switch, or spring wound
Chart Rotation Periods	24 and 48 hour, 7 day, other options
Conduit Openings	One 7/8 inch diameter hole on each side of the case for 1/2 inch conduit fitting; drill guide hole spotted in the rear of the case showing optional rear conduit location.
Air Hookup	1/4-NPT inlet and outlet openings at top and back of case
Air Input Requirements	Approximately 16 psi to 20 psi
Air Output Pressure	3 to 15 psi
Air Consumption	6 cfm maximum
Throttling Span	Adjustable from 7 to 35% of element range
Load Error Adjustment	Manual reset for load error compensation
Control Action	Reverse or Direct Acting. (Factory set -reverse, field changeable to direct acting.)
Air Gauges	Inlet and outlet - both gauges provide for English and Metric scales.
Approx. Net Weight*	9 1/2 lbs
Approx. Shipping Weight*	10 3/4 lbs

* Weight may vary depending on element length.

Note:
It is strongly recommended that Partlow equipped applications incorporate a high or low limit protective device which will shut down the equipment at a preset temperature condition in order to preclude possible damage to property or product.

This document should accompany the instrument to its final installation in order to provide operational and service assistance to the end user.

RFA ORDER MATRIX

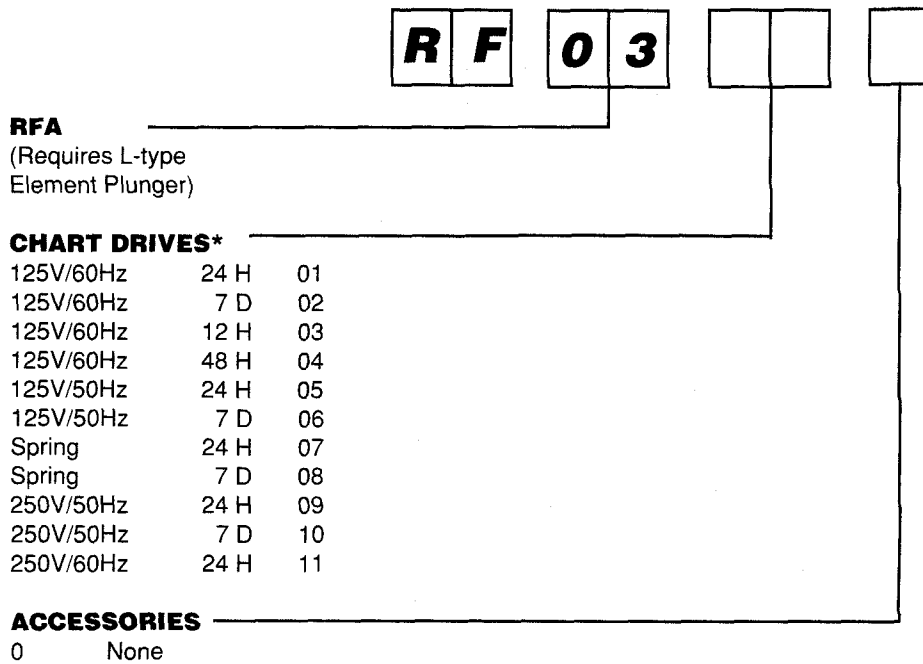

* Price includes 100 ink type charts.

PISTON-PAK THERMAL SENSING ELEMENT

A Piston-Pak Thermal Sensing Element must be specified for each RFA. Use Partlow Form 3028 "Mechanical Instrumentation Products Cross Reference and Pricing Guide" to configure the matrix number for the sensing element.

INSTALLATION

LOCATION

The element head assembly is subject to ambient temperature limitations of -30°F to 125°F (-35°C to 52°C) for low temperature head assemblies, and 32°F to 150°F (0°C to 66°C) for high temperature head assemblies. These temperature limitations must be considered when determining the instrument's location. It should be located in an area as free from vibration as possible.

MOUNTING

The instrument(s) are shipped to be surface mounted. Figure 1 illustrates hole placement for surface mount condition.

Note: Holes in brackets supplied are 9/32 clearance holes for 1/4" bolts. The four holes called out in the drawing may be any size that will accommodate the fastening requirement, ie: 9/32 for 1/4" thru-bolt with nut fastening, or #7 drill for 1/4" x 20 NC tapped hole fastening or #3 drill for 1/4" x 28 NF tapped hole fastening.

The instrument may also be flush mounted. This is accomplished by removing the two surface mounting angle brackets from the instrument. Figure 1A illustrates panel cut out dimensions. Cut the panel opening to 13 1/2" x 12 5/8". Drill 9/32 clearance holes in four locations if 1/4" thru-bolt with nut installation is desired. Should a tapped hole be preferable, drill a #7 hole in four locations for 1/4" x 20 NC or a #3 hole in four locations for a 1/4" 28 NF. **Note: All configurations require a flat head screw for proper door operation. With the instrument in the upright position, insert it and the element with the panel opening and tilt into place.**

Depending upon your panel size it may be easier to make electrical connections before finally securing the instrument into the panel.

WIRING (Omit if instrument is spring driven)

The conduit hole will be used to make all electrical connections through. Make necessary electrical connections using short sections of flexible cable or conduit according to applicable electrical codes, ordinances and regulations regarding use of conduit etc. Next access the electrical terminal block located behind the platen (to the right of the chart drive switch). Remove the terminal insulator and wire power to the terminal according to local N.E.C. codes. Use Figure 2 for hook up connections. Replace the insulator after wiring is complete.

Note: When the panel is not accessible from behind, it will be more convenient to rock the control back out of opening, make electrical and pneumatic connections before finally securing the instrument into the panel. When wiring, use rear conduit hole (spotted for drilling; see Figure 9 for location). For Pneumatic hook up, use rear distribution block opening. Remove screwdriver plugs from rear and reinstall the holes on top of instrument case. Use flexible tubing for air-line hook up. Once both have been connected, place and secure the instrument into the opening.

PLACING THE THERMAL SENSING ELEMENT

Locate the thermal sensing bulb in the most agitated part of the medium to be measured and completely immerse it. (When U and Y type bulbs are used, note separation coupling between bulb and capillary). Be sure to immerse the element up to the coupling for correct temperature indication. Do not bend capillary to less than 1/2 inch radius and never bend it too close to the element bulb or element head. Pencil type bulbs must never be bent as this will affect instrument accuracy. U and Y-type bulbs may be bent but never to less than a two inch radius. Anchor the excess capillary securely to prevent vibration damage. These bulbs may be elevated up to 40 feet above the instrument without affecting calibration. For elevations over 40 feet consult with your local Partlow Representative, Distributor or the Factory.

Figure 1 - Surface Mount Dimensions

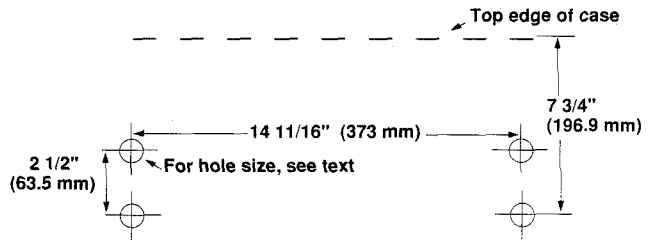

Figure 1A - Panel Cutout Illustration (in inches)

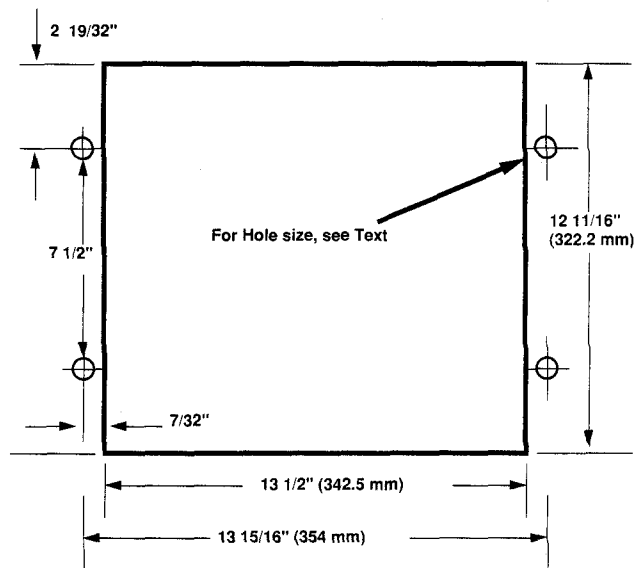
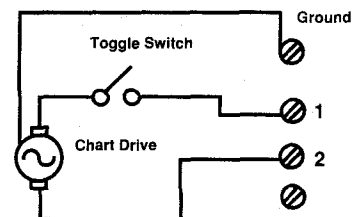

Figure 2 - Wiring Connections



STUFFING BOX INSTALLATION (IF APPLICABLE)

Overtightening of 21-T-105 steel or stainless steel stuffing boxes can damage the thermal element by restricting the capillary bore. To prevent damage, the stuffing box gland nut should be turned 1/2 to 3/4 of a revolution from a finger tight position. This is equivalent to a torque of 65 to 100 inch-pounds for steel and 130 to 180 inch-pounds for stainless steel.

PNEUMATIC HOOKUP

Clean, dry air is essential for trouble-free operation. In most cases, an adequate air filter must be installed in the air line ahead of the control to remove dirt, water, oil, and other foreign matter. Be sure that the filter used will eliminate all oil-mist and moisture, and is easily cleanable. It is recommended that a shut off valve be installed in the air line ahead of the filter to permit the cleaning of accessories without shutting down the entire system. To assure a constant uniform supply of air to the control, an air regulator (with gauge) should be installed in the line ahead of the control. When the control is hooked up to devices requiring large volumes of air (due to their size or long signal lines), a **volume booster** air relay may be necessary between the control and the device to provide the required valve sensitivity. Be sure that inlet and outlet air lines are connected as designated. The instrument will not function if the air lines are reversed.

Caution: Be sure that the valve used with the Partlow control is adjusted to produce its full travel between 3 and 15 psi.

Note: After pressurizing the system, all fittings should be checked for leakage. This may be accomplished by brushing soap-water solution over the connections and looking for bubbles.

INSTRUMENT OPERATION

Prior to putting the instrument into service, check it against an accurate test thermometer. As with any precision instrument minor adjustments may be necessary after shipment and installation. If you are unfamiliar with how to perform this check refer to the CHECKING TEMPERATURE and RE-ZEROING section of this document, below.

Control temperature is set by turning the setting lever inside the hinged cover and positioning the red set pointer along the chart to the desired temperature. The recorder pen moves upscale or downscale in response to the Piston-Pak thermal sensing element. As the pen arm enters the throttling range and approaches set point temperature, the effective size of the mechanism bleed valve is changed, which, in turn increases or decreases (depending on control action setting, reverse or direct) the pressure signal delivered to the controlled device.

The pressure signal transmitted by the instrument determines the position of the air-operated device which, either directly or indirectly, regulates the flow of heating or cooling medium to the application. When set point temperature is changed, creating a different heating or cooling demand, a new balanced condition between the air signal, valve position and medium flow is established and maintained. Any associated load error can be nullified by making an adjustment to the manual reset screw inside the instrument case, see Manual Reset Adjustment in the MAINTENANCE section.

MAINTENANCE

CHECKING TEMPERATURE

When checking and verifying your temperature be sure to use a test thermometer of known accuracy. Position the test thermometer sensing bulb or probe adjacent to the thermal sensing bulb from the RFA. Position the red set pointer along chart to the desired process temperature. Wait for the temperature to stabilize, then compare the test thermometer reading with that of the RFA. If the two readings do not agree, the RFA should be re-zeroed.

RE-ZEROING

Be sure that the process temperature is stable. Open instrument cover and loosen the set screw S (Figure 3, at right). Zeroing is accomplished by turning hex shaft J with the wrench provided. Lengthening shaft J (counterclockwise) raises pen indicated temperature, shortening shaft J (clockwise) lowers pen reading. Position the red set pointer to the high end of the chart and shut off the air supply to the instrument; then turn shaft J accordingly and correct the pen reading the **same number of degrees**. Re-tighten set screw S. Return the red set pointer to its original setting and turn the air supply back on. Check the adjustment by allowing the temperature to stabilize and compare the readings. Repeat these steps if necessary.

REVERSE OR DIRECT ACTING SETTING

Instruments are shipped with the mechanisms adjusted for reverse action, to provide a decrease in air pressure with an increase in temperature. If direct acting setting is desired, to provide an increase in air pressure with an increase in temperature, loosen the slotted machine screw on valve assembly E. (Figure 4, at right) Rotate the entire valve until the slotted screw is tight against the opposite end of the adjustment slot in the mechanism bracket. Tighten screw. When in position, a letter D is visible at 4 o'clock on the mechanism rotary valve. In reverse acting setting, no letter is visible.

Note: After action setting change, it may be necessary to make a manual reset adjustment, see **MANUAL RESET ADJUSTMENT** section (below).

THROTTLING RANGE ADJUSTMENT

Throttling range is adjusted by moving selector knob K (Figure 4, at right) along the mechanism slider scale. The narrowest range is at the top of the scale, widest at the bottom. To set the range, loosen selector knob K (turn counterclockwise), slide the knob upscale or downscale, as required, until proper range (stable temperature pen-line on chart) has been established, and re-tighten the knob.

Note: At start-up, Partlow recommends an approximate mid-range setting.

MANUAL RESET ADJUSTMENT

Hex head screw M (Figure 5, at right) is the manual reset adjustment. The control is shipped with the screw adjusted to mid range pressure (9 psi), which means that screw M is set so that the pen-indicated temperature is in agreement with the set pointer at control output pressure of 9 psi.

Because load error is an inherent characteristic of all throttling type devices, the recording pen may settle out either slightly lower or higher than the set temperature (set pointer). When the pen settles out above set pointer, using the wrench provided slightly back out (turn counterclockwise) screw M. This will re-position the valve (in relation to the set pointer) and allow the pen to move back into alignment. If the pen settles out below the set temperature, turn screw M slightly inward (clockwise). After each screw M adjustment allow adequate time for the pen to settle out. Repeat these steps if necessary.

TO CLEAN ORIFICE

Orifice screw H is located behind the platen in the upper section. Shut off air supply and remove platen. Remove hex-head orifice screw H using 1/2" socket wrench. Note orifice located in the side of the screw. Clean orifice using shank end of No. 77 drill (.018" dia.) or wire equivalent. Care should be taken not to enlarge orifice. With orifice screw out of the block, open the air supply to flush out the system. Reinstall orifice screw in distribution block.

Figure 3 - Re-Zeroing

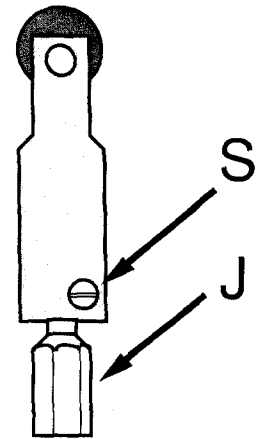

Figure 4 - Reverse or Direct Acting setting and Throttling Range Adjustment

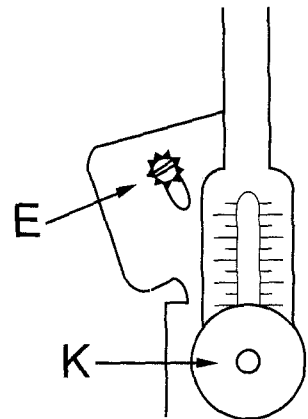
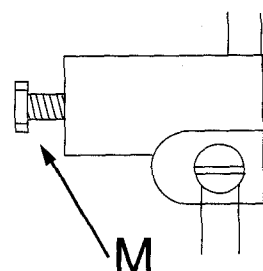

Figure 5 - Manual Reset Adjustment



BRAKE TIGHTENING

Periodically the setting shaft brake may require tightening. If the brake is too loose, the overtravel movement of the black indicating pointer will tend to drag the set pointer upscale from its set position. To tighten the brake, turn the adjustment screw U clockwise (Figure 6, below). Do not over-tighten.

PISTON-PAK THERMAL SENSING ELEMENT IDENTIFICATION

An element designation number is stamped on the bottom of the element head. This is a coded description of the element specifications and should be used whenever a replacement element is ordered. The number appearing on the side of the element head (Figure 7, below) is the element age code, which may be required in establishing warranty.

ORDERING SPECIFYING THE PISTON-PAK SENSING ELEMENT

The sensing element is ordered separately from the RFA and requires its own matrix number. To determine the correct sensing element configuration for your instrument(s) and application, see Partlow Form 3028 "Mechanical Instrumentation Products Cross Reference and Pricing Guide."

ELEMENT REPLACEMENT

To change a thermal sensing element, start by removing screws D (Figure 8, below) and withdrawing the element from the instrument body. Then remove the element bulb from the medium. Install the new element and replace screws D. Insert the new element bulb into the medium being measured.

Note: After the element has been replaced, check the temperature setting, re-zeroing may be necessary. If so, see the CHECKING TEMPERATURE section (page 4).

Caution: The inside mechanism(s), particularly the inside of the element housing, should never be oiled. However, if the instrument is subject to corrosion or gunking conditions, the mechanical linkage should be sprayed periodically with corrosion inhibiting CRC2-26, 3-36, or 5-56. Use only CRC2-26, 3-36, or 5-56 as other lubricants may cause build up and sticking of internal parts. Also note that the latch handle assembly should never be lubricated with any chemical. On plastic type door housings the latch may be lubricated using graphite. On aluminum dye cast type door housings, the latch may be lubricated using the same lubricant used on the mechanism. CRC2-26 may be purchased from Partlow in a 15 oz. container (part #63600401). CRC5-56 may be purchased locally from any hardware or automotive store.

Figure 6 - Brake Tightening

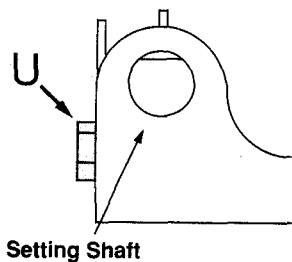

Figure 7 - Element ID

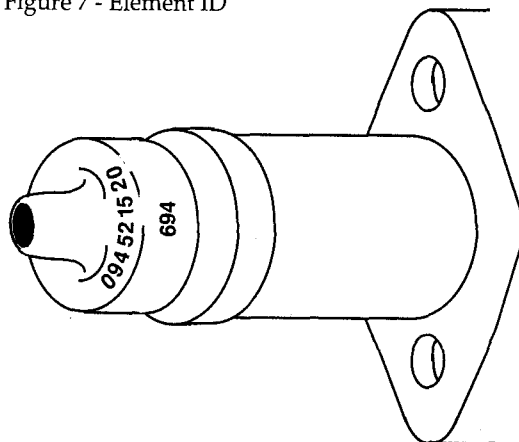
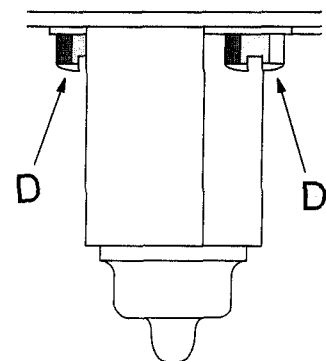

Figure 8 - Element Replacement



DIMENSIONAL DRAWING

Figure 9 - Dimensional Drawing

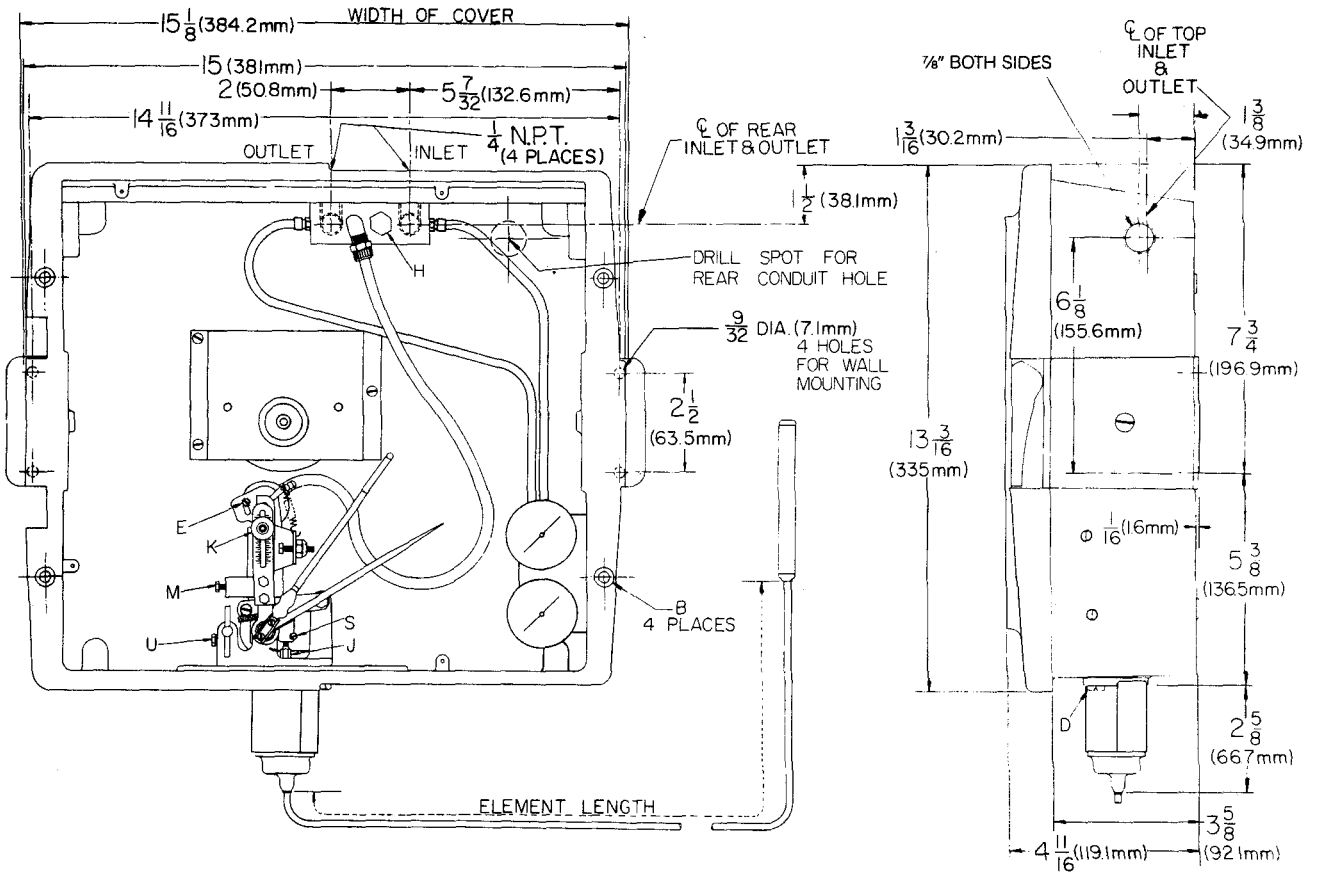
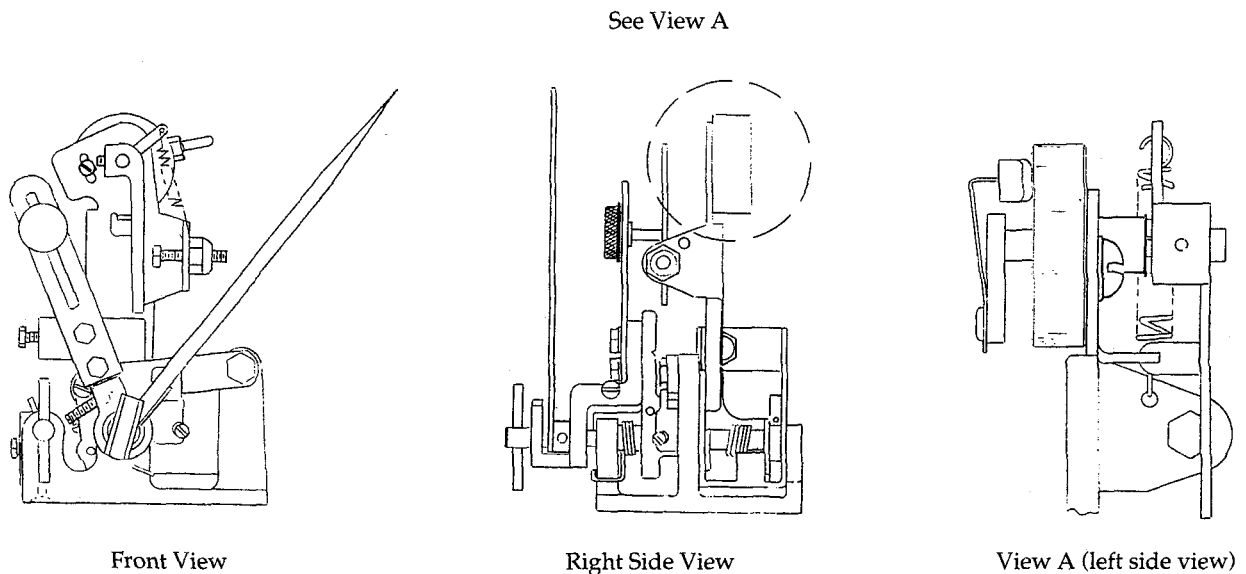

Figure 10 - Mechanism Drawing



EXPLODED ILLUSTRATION AND PARTS LIST

- 1. Case Assembly** 64415103
Includes: Case, Ground Plane, Latch Bracket, Mounting brackets with screws, hinge pins and plates, hub strip hinge.
- 2. Cover Assembly** 10067402
Includes: Cover glass, Gauge glass, glass retaining ring, gaskets, latch handle assembly.
- 3. Mechanism Assembly** 10068604
Includes: Entire mechanism including air line, setpoint pointer, pen, cartridge, push rod, and set screw.
- 4. Main Lever Assembly** 64414801
Includes: Main lever with push rod cap, push rod, set screw.
- 5. Terminal Block Kit**
Includes: Terminal Block, Insulator, Miscellaneous Hardware
For 3 Positions 64415001
For 6 Positions 64415002
For 9 Positions 64415003
- 6. Chart Nut and Flange Kit**
Includes: Hub nut, Retaining clip and Flange Assembly.
For Stand Mounted Chart Drives 64415201
For Platen Mounted Chart Drives 64415202
For Stand Mounted Spring Wound Chart Drives with turrets. Only nut and clips are included. 64415204
- 7. Chart Hub Namestrip** RFS12
For CCW chart rotation

- 8. Air Distribution Block Assembly** SPRFAS2B
Includes: Block, Orifice, "O" Rings, Gasket, Plastic Barbed Fittings.
- 9. Fixed Orifice Device** 64414201
Includes: Orifice and "O" Rings
- 10. Chart Drive**
Contact factory for re-order. Specify time base, voltage, cycle, and stand or platen mounted device being replaced
- 11. Chart Drive Mounting Stand**
(Not required for Platen mounted drives)
Includes: All fasteners and Clamp Plate.

For All Electric Stand Mounted 64415601
For 24 Hour & 7 Day Spring Wound 64415602
For other Spring Wound with Turret 64415603
- 12. Platen Assembly** SP10067701
For Spring Wound or Electric Drives, Stand or Platen mounted.
- 13. Gauges** SPRFAS6
Includes: Inlet and Outlet Gauges, Bracket and Rear Fittings.
- 14. Hardware Kit (not shown)** 64415701
Includes: All Body Fasteners (may include fasteners not required for specific models)

Warranty

These products are sold by The Partlow Corporation ("Partlow") under the warranties set forth in the following paragraph. Such warranties are extended only with respect to a purchase of these products, as new merchandise, directly from Partlow or from a Partlow distributor, representative or reseller, and are extended only to the first buyer thereof who purchases them other than for the purpose of resale.

These products are warranted to be free from functional defects in materials and workmanship at the time the products leave the Partlow factory, and to conform at that same time to the specifications set forth in the relevant Partlow instrumentation sheet, sheets, manual or manuals for such products.

Partlow's sole and exclusive obligation and buyer's sole and exclusive remedy under the above warranties is limited to repairing or replacing, at Partlow's option free of charge, the products which are reported in writing to Partlow at its main office - The Partlow Corporation, 2 Campion Road, New Hartford, New York 13413 or FAX MAIL 1-315-797-0403 and which if so advised by Partlow, are returned with a statement of the observed deficiency to the designated facility during normal business hours, transportation charges prepaid and which upon examination by Partlow are found not to comply with the above warranties. PARTLOW SHALL NOT BE LIABLE FOR ANY INCIDENTAL DAMAGES, CONSEQUENTIAL DAMAGES, SPECIAL DAMAGES, OR ANY OTHER DAMAGES, COSTS OR EXPENSES, EXCEPTING ONLY THE COST OR EXPENSE OF REPAIR OR REPLACEMENT AS ABOVE DESCRIBED.

THERE ARE NO EXPRESSED OR IMPLIED WARRANTIES WHICH EXTEND BEYOND THE WARRANTIES HEREIN ABOVE SET FORTH. PARTLOW MAKES NO WARRANTY OR MERCHANTABILITY OR FITNESS FOR A PARTICULAR PURPOSE WITH RESPECT TO THE PRODUCTS.



Form Number 3167
Pub. March 1991
First Edition

Represented/Distributed By:

