MIC 1160

1/16 DIN MICROBASED CONTROLLER

OPERATORS
MANUAL
FORM 3478
EDITION 3
© MARCH 1996
UPDATED 11/96
PRICE \$10.00



Information in this installation, wiring, and operation manual is subject to change without notice. One manual is provided with each instrument at the time of shipment. Extra copies are available at the price published on the front cover.

Copyright © March 1996, The Partlow-West Company, all rights reserved. No part of this publication may be reproduced, transmitted, transcribed or stored in a retrieval system, or translated into any language in any form by any means without the written permission of the Partlow-West Company.

This is the Third Edition of the MIC 1160 manual. It was written and produced entirely on a desk-top-publishing system. Disk versions are available by written request to The Partlow-West Company Publications Department.

We are glad you decided to open this manual. It is written so that you can take full advantage of the features of your new MIC 1160 process controller.

NOTE:

It is strongly recommended that Partlow equipped applications incorporate a high or low limit protective device which will shut down the equipment at a preset process condition in order to preclude possible damage to property or products.

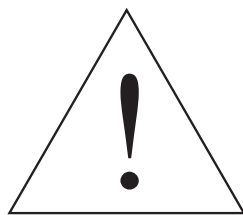

THE INTERNATIONAL HAZARD SYMBOL IS INSCRIBED ADJACENT TO THE REAR CONNECTION TERMINALS. IT IS IMPORTANT TO READ THIS MANUAL BEFORE INSTALLING OR COMMISSIONING THE UNIT.

Table of Contents

Section 1 - General	Page
1.1 Product Description	5
Section 2 - Installation & Wiring	
2.1 Installation & Wiring	7
2.2 Preparations for Wiring	9
2.3 Input Connections	14
2.4 Output Connections	16
Section 3 - Configuration & Operation	
3.1 Operation	19
3.2 Configuration	24
3.3 Pre-Tune Mode	31
3.4 Auto-Tune Mode	31
3.5 Manual Tuning Method	34
Section 4 - Control Capability	
4.1 Control Capability	35
4.2 Control Responses	35
4.3 Direct/Reverse Operation of Control Outputs	35
4.4 On-Off Control	36
4.5 Time Proportioning Control	36
4.6 Current Proportioning Control	37
4.7 Setpoint Adjustments	38
Appendices	
A - Glossary of Terms	39
Figure A-1 Proportional Band & Deadband/Overlap	49
B - Board Layout - Jumper positioning	50
Figure B-1 Exploded View & Board Layout	50
Figure B-2 CPU PWA with Relay or SSR Output 1	51
Figure B-3 CPU PWA with DC Output 1	52
Figure B-4 Option PWA DC Output 2/Output 3	53
C - Hardware Definition Code	54
D - Input Range Codes	56
E - Specifications	58
F - Model Number Hardware Matrix	64
G - Software Reference Sheet	65

Figures & Tables

Figure 1-1	Controller Display Illustration	6
Figure 2-1	Panel Cut-Out Dimensions	7
Figure 2-2	Main Dimensions	8
Figure 2-3	Panel Mounting the controller	8
Figure 2-4	Noise Suppression	11
Figure 2-5	Noise Suppression	12
Figure 2-6	Wiring Label	13
Figure 2-7A	Main Power Supply	14
Figure 2-7B	24V AC/DC Power Supply	14
Figure 2-8	Thermocouple Input	14
Figure 2-9	RTD Input	15
Figure 2-10	Volt, mV mADC Input	15
Figure 2-11	Remote Digital Connections	16
Figure 2-12	Relay Output 1	16
Figure 2-13	SSR Driver Output 1	16
Figure 2-14	mADC Output 1	17
Figure 2-15	Relay Output 2	17
Figure 2-16	SSR Driver Output 2	17
Figure 2-17	mADC Output 2	17
Figure 2-18	Relay Output 3	18
Figure 2-19	SSR Driver Output 3	18
Figure 2-20	mADC Output 3	18
Figure 3-1	Temperature Application	33
Figure 3-2	Pre-Tune disturbing start-up	33
Figure 4-1	Proportional Bandwidth Effect on Output	37
Table 3-1	Enable Mode Configuration Procedures	24
Table 3-2	Program Mode Configuration Procedures	25
Table 3-3	Tune Mode Configuration Procedures	27

Product Description 1.1

1.1.1 GENERAL

This instrument is a microprocessor based single loop controller capable of measuring, displaying and controlling temperature, pressure, flow, and level from a variety of inputs. Most outputs are easily tuned using the instrument Pre-Tune and Auto-Tune functions.

Control functions, alarm settings and other parameters are easily entered through the front keypad. E² Technology (100 year life) protects against data loss during AC power outages.

The input is user configurable to directly connect to either thermocouple, RTD, mVDC, VDC or mADC inputs. The instrument can operate from either a 90-264 VAC, 50/60 HZ power supply, or optional 24V AC/DC power supply.

1.1.2 DISPLAYS

Each instrument is provided with dual displays and status indicators as shown in Figure 1-1. The upper display displays the value of the process variable. The lower display displays the setpoint value. Status indication is as shown, see Figure 1-1, page 6.

1.1.3 CONTROL

The instrument can be programmed for on-off, time proportioning, or current proportioning control implementations depending on the model number. A second control output is an available option. Proportional control implementations are provided with fully programmable PID parameters.

1.1.4 ALARMS

Alarm indication is standard on all instruments. Up to two alarm outputs are possible. Alarm type may be set as Process Direct or Reverse (high or low), Deviation Direct or Reverse (above or below setpoint), Deviation Band Type (closed or open within band), or Loop Reverse or Direct. Alarm status is indicated by LED.

FIGURE 1-1
Keys and Indicators



1.1.5 PROCESS VARIABLE/SETPOINT VALUE

RE-TRANSMISSION OUTPUT

If the instrument is specified with this option, this output may be scaled over any desired range and re-transmitted.

Installation and Wiring 2.1

Electrical code requirements and safety standards should be observed and installation performed by qualified personnel.

The electronic components of the instrument may be removed from the housing during installation. To remove the components, grip the side edges of the front panel and pull the instrument forward. During re-installation, the vertically mounted circuit boards should be properly aligned in the housing.,

Ensure that the instrument is correctly orientated. A stop will operate if an attempt is made to insert the instrument incorrectly.

Recommended panel opening sizes are illustrated in Figure 2-1. After the opening is properly cut, insert the instrument into the panel opening. Ensure that the panel gasket is not distorted and that the instrument is positioned squarely against the panel. Slide the mounting clamp into place on the instrument (see Figure 2-3, page 8) and push it forward until it is firmly in contact with the rear face of the mounting panel.

Note: The mounting clamp tongues may engage either on the sides or the top/bottom of the instrument housing. Therefore, when installing several instruments side-by-side in one cut out, use the ratchets on the top/bottom faces.

FIGURE 2-1
Panel Cut-Out Dimensions

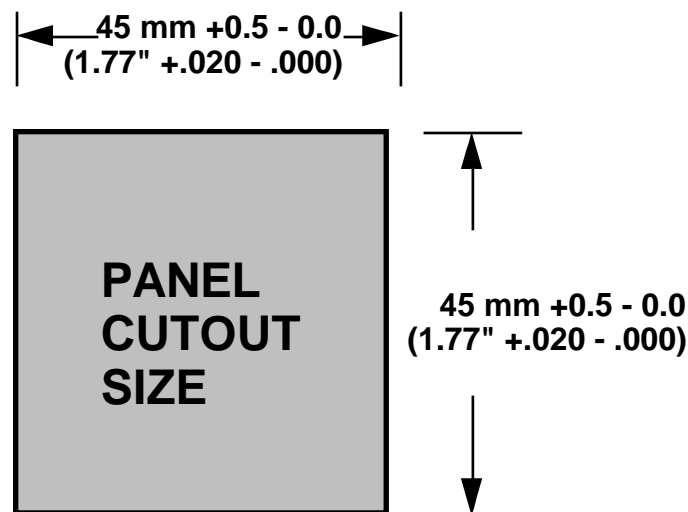

FIGURE2-2
Main Dimensions

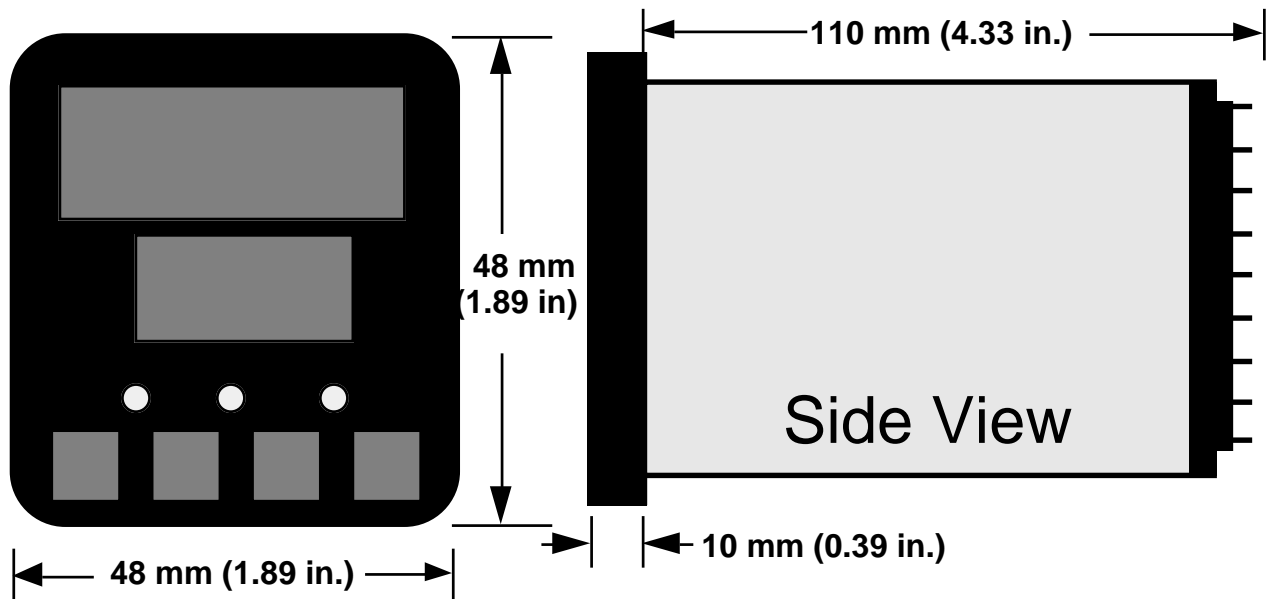
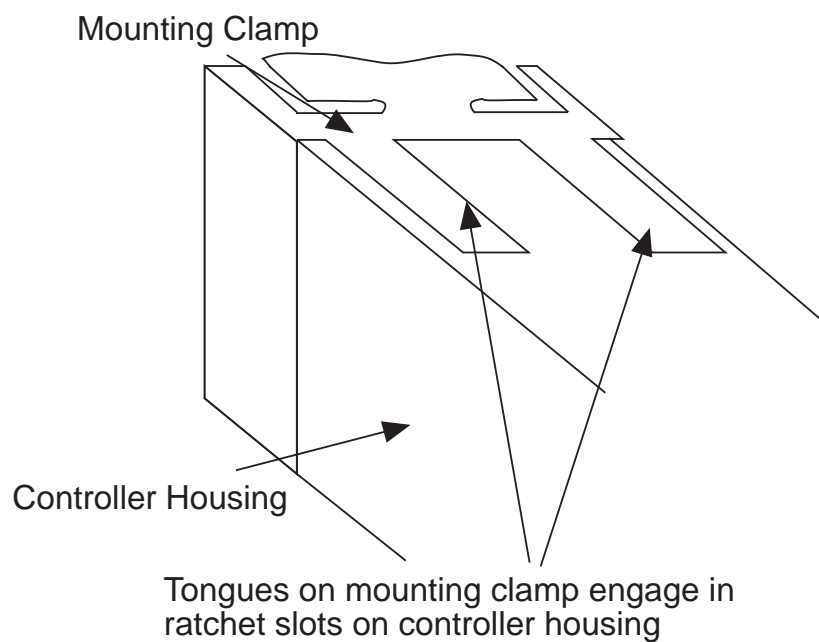

FIGURE2-3
Panel Mounting the Controller



Preparation for Wiring 2.2

2.2.1 WIRING GUIDELINES

Electrical noise is a phenomenon typical of industrial environments. The following are guidelines that must be followed to minimize the effect of noise upon any instrumentation.

2.2.1.1 *INSTALLATION CONSIDERATIONS*

Listed below are some of the common sources of electrical noise in the industrial environment:

- Ignition Transformers
- Arc Welders
- Mechanical contact relay(s)
- Solenoids

Before using any instrument near the device listed, the instructions below should be followed:

1. If the instrument is to be mounted in the same panel as any of the listed devices, separate them by the largest distance possible. For maximum electrical noise reduction, the noise generating devices should be mounted in a separate enclosure.
2. If possible, eliminate mechanical contact relay(s) and replace with solid state relays. If a mechanical relay being powered by an instrument output device cannot be replaced, a solid state relay can be used to isolate the instrument.
3. A separate isolation transformer to feed only instrumentation should be considered. The transformer can isolate the instrument from noise found on the AC power input.
4. If the instrument is being installed on existing equipment, the wiring in the area should be checked to insure that good wiring practices have been followed.

2.2.1.2 AC POWER WIRING

Neutral (For 115 VAC)

It is good practice to assure that the AC neutral is at or near ground potential. To verify this, a voltmeter check between neutral and ground should be done. On the AC range, the reading should not be more than 50 millivolts. If it is greater than this amount, the secondary of this AC transformer supplying the instrument should be checked by an electrician. A proper neutral will help ensure maximum performance from the instrument.

2.2.1.3 WIRE ISOLATION

Four voltage levels of input and output wiring may be used with the unit:

- Analog input or output (i.e. thermocouple, RTD, VDC, mVDC, or mADC)
- SPDT Relays
- SSR driver outputs
- AC power

The only wires that should run together are those of the same category. If they need to be run parallel with any of the other lines, maintain a minimum 6 inch space between the wires. If wires must cross each other, do so at 90 degrees. This will minimize the contact with each other and reduces “cross talk”. “Cross Talk” is due to the EMF (Electro Magnetic Flux) emitted by a wire as current passes through it. This EMF can be picked up by other wires running in the same bundle or conduit.

In applications where a High Voltage Transformer is used (i.e. ignition systems) the secondary of the transformer should be isolated from all other cables.

This instrument has been designed to operate in noisy environments, however, in some cases even with proper wiring it may be necessary to suppress the noise at its source.

2.2.1.4 USE OF SHIELDED CABLE

Shielded cable helps eliminate electrical noise being induced on the wires. All analog signals should be run with shielded cable. Connection lead length should be kept as short as possible, keeping the wires protected by the shielding. The shield should be grounded at one end only. The preferred grounding location is the sensor, transmitter or transducer.

2.2.1.5 NOISE SUPPRESSION AT THE SOURCE

Usually when good wiring practices are followed no further noise protection is necessary. Sometimes in severe electrical environments, the amount of noise is so great that it has to be suppressed at the source. Many manufacturers of relays, contactors, etc. supply “surge suppressors” which mount on the noise source.

For those devices that do not have surge suppressors supplied, RC (resistance-capacitance) networks and/or MOV (metal oxide varistors) may be added.

Inductive Coils - MOV's are recommended for transient suppression in inductive coils connected in parallel and as close as possible to the coil. See Figure 2-4. Additional protection may be provided by adding an RC network across the MOV.

FIGURE 2-4

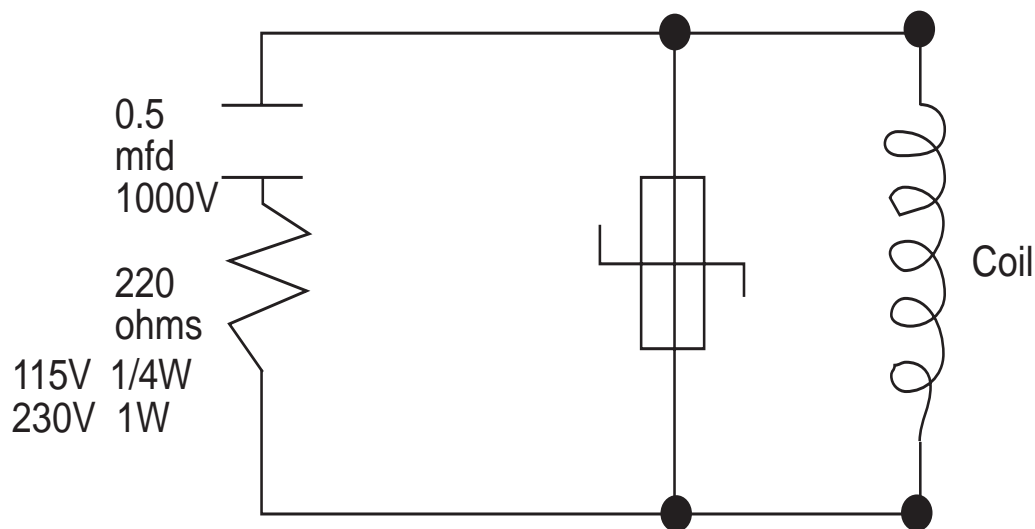

Contacts - Arcing may occur across contacts when the contact opens and closes. This results in electrical noise as well as damage to the contacts. Connecting a RC network properly sized can eliminate this arc.

For circuits up to 3 amps, a combination of a 47 ohm resistor and 0.1 microfarad capacitor (1000 volts) is recommended. For circuits from 3 to 5 amps, connect 2 of these in parallel. See Figure 2-5, page 12.

FIGURE 2-5

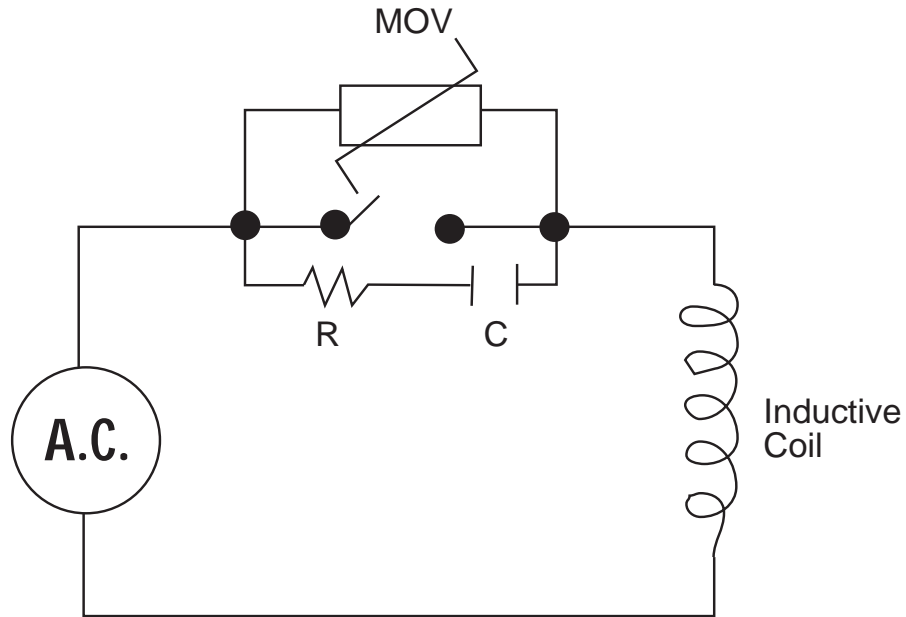

2.2.2 SENSOR PLACEMENT (Thermocouple or RTD)

Two wire RTD's should be used only with lead lengths less than 10 feet.

If the temperature probe is to be subjected to corrosive or abrasive conditions, it should be protected by the appropriate thermowell. The probe should be positioned to reflect true process temperature:

In liquid media - the most agitated area

In air - the best circulated area

FIGURE 2-6
Wiring Label

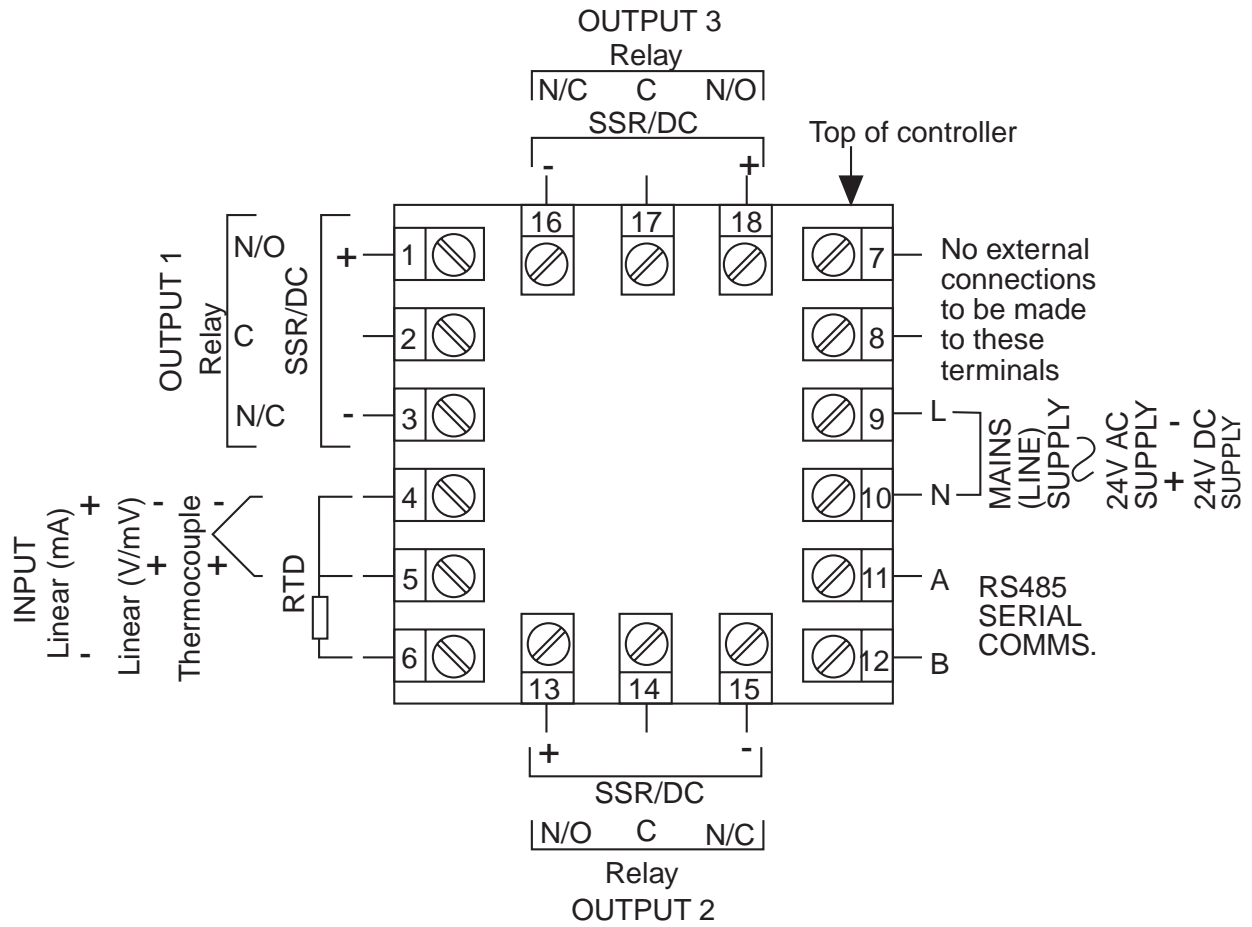

Input Connections 2.3

In general, all wiring connections are made to the instrument after it is installed. Avoid Electrical Shock. AC power wiring must not be connected to the source distribution panel until all wiring connection procedures are completed.

FIGURE 2-7A
Main Supply

The instrument will operate on 90-264V AC 50/60Hz main supply. The power consumption is approximately 4 VA. Connect the line voltage, hot and neutral, to terminals 9 to 10 respectively as illustrated below.

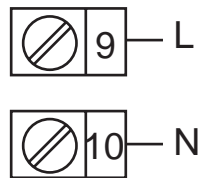

FIGURE 2-7B

24V (Nominal) AC/DC Supply

The supply connections for the 24V AC/DC versions of the instrument are shown below.

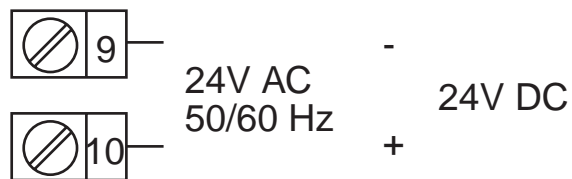

FIGURE 2-8

Thermocouple (T/C) Input

Make thermocouple connections as illustrated below. Connect the positive leg of the thermocouple to terminal 5 and the negative leg to terminal 4.

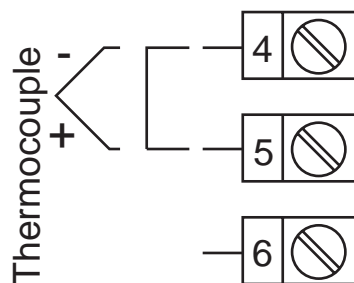

FIGURE2-9

RTD Input

Make RTD connections as illustrated below. For a three wire RTD, connect the resistive leg of the RTD to terminal 6 and the common legs to terminals 4 and 5. For a two wire RTD, connect one leg to terminal 5 and the other leg to terminal 6 as shown below. A jumper wire supplied by the customer must be installed between terminals 4 and 5. Input conditioning jumper must be positioned correctly (see Appendix B) and Hardware Definition Code must be correct (see Appendix C).

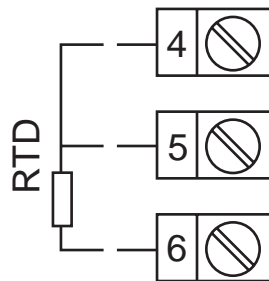

FIGURE2-10

Volt, mV Input

Make volt and millivolt connections as shown below. Terminal 5 is positive and terminal 4 is negative. Input conditioning jumper must be positioned correctly (see Appendix B) and Hardware Definition Code must be correct (see Appendix C).

mADC Input

Make mADC connections as shown below. Terminal 4 is positive and terminal 6 is negative. Input conditioning jumper must be positioned correctly (see Appendix B) and Hardware Definition Code must be correct (see Appendix C).

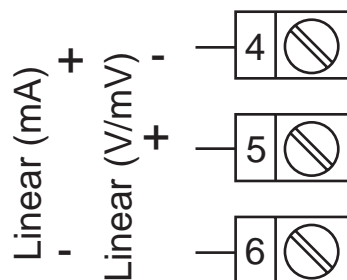
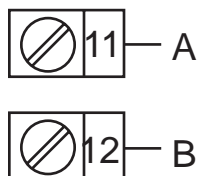

FIGURE2-11

Remote Digital Communications - RS485

Make digital communication connections as illustrated below.



Output Connections 2.4

FIGURE2-12

Relay Output 1 (Control Output 1)

Connections are made to Output 1 relay as illustrated below. The contacts are rated at 2 amp resistive, 120/240 VAC.

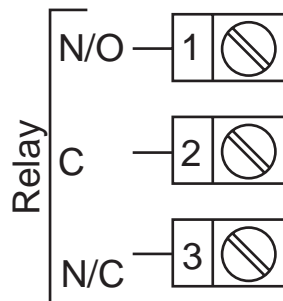

FIGURE2-13

SSR Driver Output 1 (Control Output 1)

Connections are made to Output 1 SSR Driver as illustrated below. The solid state relay driver is a non-isolated 0-4 VDC nominal signal. Output impedance is 250 ohms.

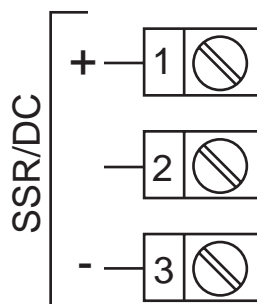

FIGURE2-14

mADC Output 1 (Control Output 1)

Make connections for DC Output 1 as illustrated below.

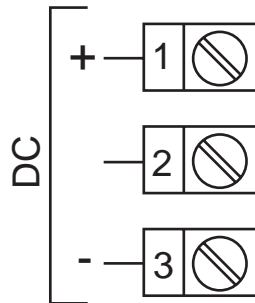

FIGURE2-15

Relay Output 2 (Control Output 2 OR Alarm 2)

Connections are made to Output 2 relay as illustrated below. The contacts are rated at 2 amp resistive, 120/240 VAC.

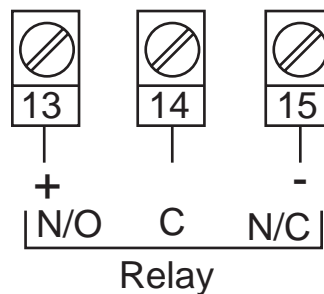

FIGURE2-16

SSR Driver Output 2 (Control Output 2 OR Alarm 2)

Connections are made to Output 2 SSR Driver as illustrated below. The solid state relay driver is a non-isolated 0-4 VDC nominal signal. Output impedance is 250 ohms.

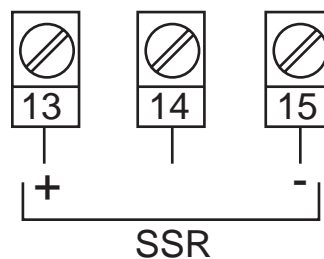

FIGURE2-17

mADC Output 2 (Control Output 2)

Make connections for DC Output 2 as illustrated below.

(Continued on next page)

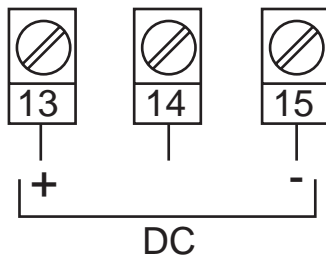

FIGURE2-18

Relay Output 3 (Alarm 1)

Connections are made to Output 3 relay as illustrated below. The contacts are rated at 2 amp resistive, 120/240 VAC.

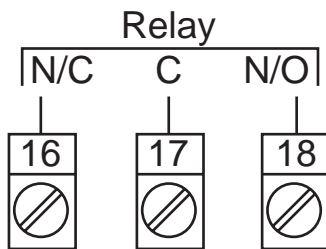

FIGURE2-19

SSR Driver Output 3 (Alarm 1)

Connections are made to Output 3 SSR Driver as illustrated below. The solid state relay driver is a non-isolated 0-4 VDC nominal signal. Output impedance is 250 ohms.

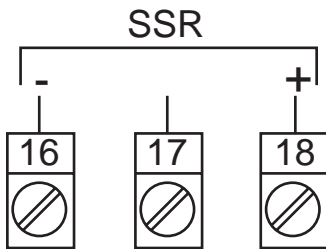
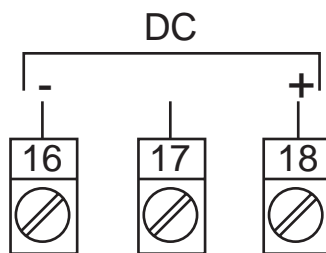

FIGURE2-20

mADC Output 3 (Recorder Output Only)

Make connections for DC output 3 as illustrated below.



Operation 3.1

3.1.1 POWERUPPROCEDURE

Verify all electrical connections have been properly made before applying power to the instrument.

If the instrument is being powered for the first time, it may be desirable to disconnect the controller output connections. The instrument will be into control following the power up sequence and the output(s) may turn ON. During power up, a self-test procedure is initiated during which all LED segments in the two front panel displays appear and all LED indicators are ON. When the self-test procedure is complete, the instrument reverts to normal operation.

Note: When power is first applied, a delay of about 3 seconds will be seen before the LEDs will light.

3.1.2 KEYPADOPERATION

AUTO/MANUAL KEY

This key is used to:

1. Enter the Auto/Manual mode and vice versa.
2. Used to activate the Auto Tune mode.
3. Used to confirm a change in the Program mode.

SCROLL KEY

This key is used to:

1. Select adjustment of the ramping setpoint, if enabled.
2. Select a parameter to be viewed or adjusted.
3. Display enabled modes of operation.
4. Display a mode parameter value.
5. Advance display from a parameter value to the next parameter code.
6. Activate the Pre-tune mode.
7. With the DOWN key to view the current Hardware Definition Code setting.

UP KEY

This key is used to:

1. Increase the displayed parameter value.
2. Increase setpoint.
3. With the DOWN key to enter Pre and Auto Tune mode.

DOWN KEY

This key is used to:

1. Decrease the displayed parameter value.
2. Decrease setpoint.
3. With the UP key to enter the Pre and Auto Tune mode.
4. With the SCROLL key to view the current Hardware Definition Code setting.

3.1.3 DISPLAYS

During configuration the upper display shows the parameter setting. The lower display shows the parameter code for the currently selected parameter. During operation, the upper display shows the value of the process variable. The lower display shows the setpoint value.

3.1.3.1 ALARM STATUS DISPLAY*

The user may view the status of the instrument's alarm(s) by depressing the SCROLL key until the lower display shows the legend "ALSt" and the upper display shows the alarm status in the following format:

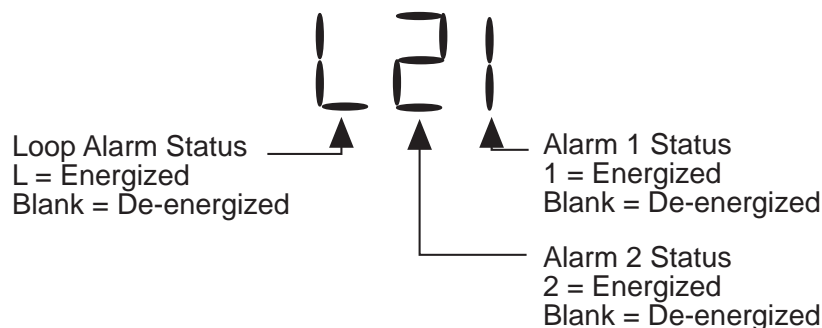

*This display is available only if one or more of the alarms is/are energized.

When "ALSt" is seen in the lower display when pressing the SCROLL key, to enter the Program or Tune modes, press the UP key with "ALSt" in the bottom display and the top display blank, then press the SCROLL key to Program or Tune.

3.1.3.2 OVER-RANGE/UNDER-RANGE DISPLAY

If the process variable attains a value higher than the input scale maximum limit, the upper display will show:

CHH3

If the process variable attains a value lower than the input scale minimum, the upper display will show:

CLL3

If a break is detected in the sensor circuit, the upper display will show:

SnSr

3.1.4 FRONT PANEL INDICATORS

- 1 Indicates the state of the Output 1 relay or SSR driver. When the indicator is ON the relay is energized or the SSR driver is ON.
- 2 Indicates the state of the Output 2 relay or SSR driver. When the indicator is ON the relay is energized or the SSR driver is ON.

ALM When flashing, indicates an Alarm condition.

MAN Flashes when the Manual mode has been entered

AT Indicates when the Pre-Tune mode or Auto-Tune mode has been selected; flashing for Pre-Tune and continuously ON for Auto-Tune.

3.1.5 SETPOINT ADJUSTMENT

3.1.5.1 LOCAL SETPOINT

To adjust the instrument setpoint, proceed as follows:

To adjust the Setpoint, press the UP or DOWN key as applicable. Momentary depression will increment or decrement (as appropriate) the setpoint by one unit in the least significant digit. (Continued on next page)

(Continued from page 21)

If the key is held for longer than 1 second, the least significant digit will change at the rate of 25 units per second. If the key is held for longer than 10 seconds, the second least significant digit will change at the rate of 25 units per second. If the key is held for more than 10 seconds, the third least significant digit will change at the rate of 25 units per second.

3.1.5.2 RAMPING SETPOINT

A selectable Ramp Rate function in the range of 1 to 9999 units per hour can be used to limit the rate at which the setpoint used by the control algorithm will change. This feature will also establish a soft start up. Upon power up, the instrument will take the initial process value as the setpoint. A setpoint ramp rate will be calculated to increase the setpoint from the initial process value to the setpoint selected. The setpoint ramp feature disables the Pre-Tune facility. The Auto-Tune facility, if selected, will commence only after the setpoint has completed the ramp.

Sudden changes in the setpoint value entered via the keypad can be inhibited from effecting the control outputs by use of this feature. The internal setpoint used to control the process will ramp to the setpoint value entered at the rate of change selected.

To view the Ramping Setpoint value while in the Control mode and "ESPr" in the Tune mode is disabled, press the SCROLL key until "SPrP" is displayed in the lower display. This is the code for the ramping setpoint value. Press the SCROLL key one more time and the lower display shows "SPrP" and the upper display will show the current ramping setpoint.

SPRr not OFF and ESPr equal to 0

PV ↻ BLANK ↻ Ramping SP ↻ PV
*SP SPrP SPrP *SP

If ESPr is enabled, the display sequence changes to:

PV ↻ BLANK ↻ Ramping SP ↻ BLANK ↻ *Ramp Rate ↻ PV
*SP SPrP SPrP SPrP SPrP *Ramp Rate SPrP *SP

*Adjustable

To enter the Program or Tune mode when setpoint ramping is selected, press the SCROLL key until the lower display shows "SPrP" or "SPrr" and the upper display is blank. With "SPrP" or "SPrr" display in the lower display, press the UP key once and "Ctrl" should be displayed in the lower display. With "Ctrl" displayed, press the SCROLL key until "Prog" or "tunE" is displayed in the lower display.

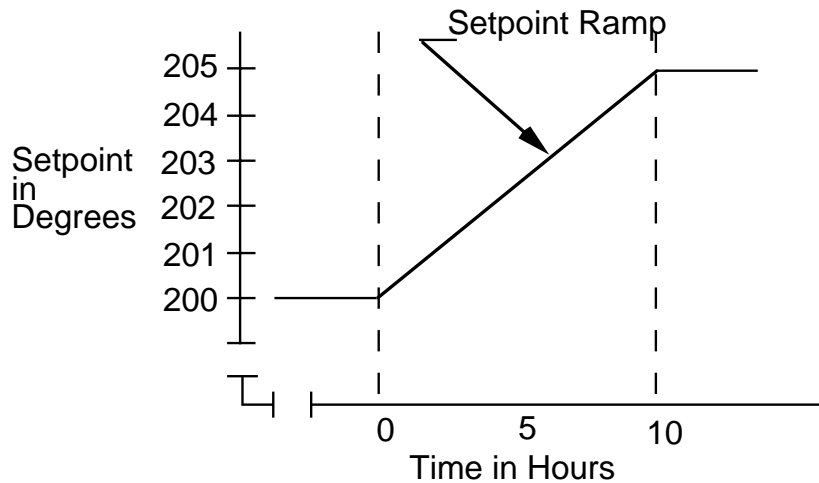

3.1.6 MANUAL CONTROL

Manual Control is not applicable if the Auto/Manual selection in Tune mode is disabled.

To enter the Manual mode, press the AUTO/MANUAL key. The Manual mode status LED will begin to flash indicating that the Manual mode is in use. Shifting from the Control to the Manual mode is bumpless. The proportional output(s) will stay at the last value(s) calculated by the control algorithm. The upper display will show the current process value. The lower display will show the current value output power in the form PXXX where X is equal to the percentage of output power. The value of output power may be adjusted using the UP and DOWN keys, as required.

The output power value can be varied in the range 0% of 100% for instruments using Output 1 only, and -100% to +100 % for instruments with both Output 1 and Output 2.

To exit from the Manual mode, press the Auto/Manual key. Shifting to the Control mode is bumpless.

Configuration 3.2

All configurable parameters are provided in Tables 3-1 through 3-3 on the following pages. These tables illustrate the display sequence, parameter adjustment and factory setting for each step.

Depression of the SCROLL key will cycle the display if Setpoint Ramp Rate is not enabled (top display is blank, lower display shows the parameter code) through all enabled modes as follows:

CONTROL ----	PROGRAM ----	TUNE
(Ctrl)	(Prog)	(tunE)

If a mode is not enabled it will be skipped over by the routine.

3.2.1 ENABLEMODE

The Enable mode provides a means of enabling or disabling access to the Program and Tune modes. If a mode has been disabled, then that mode will not be displayed or available to the user in the Control mode. See Table 3-1 (page 25) for the Enable Mode procedure.

3.2.2 PROGRAMMODE

The Program mode is used to configure or re-configure the instrument. The input and output selections are made in the Program mode. All possible parameters are illustrated in Table 3-2 (page 25). Only those parameters that are applicable to the hardware options chosen will be displayed.

3.2.3 TUNEMODE

The Tune mode is used to adjust the tuning parameters, alarm settings, setpoint limits, and retransmit scaling needed for proper operation of the instrument. See Table 3-3 (page 27) for Tune mode. Only those parameters that are applicable will be displayed.

TABLE 3-1 ENABLEMODE

To enter the Enable mode, press and hold the UP and DOWN keys. After 5 seconds (the AT LED should have flashed once), the display returns to normal. After 5 more seconds, "EnAb" will be displayed. Release the keys, the display should show "EPro". Pressing the DOWN key will display the Enable mode codes in the following sequence:

EPro - - Etun - - ESPC

Pressing the SCROLL key will display the Enable mode codes with the upper display blank. The next depression of the SCROLL key will add the Enable code status (ON or OFF) to the upper display. With the Enable code status displayed, use the UP key to change the status to ON and the DOWN key to change the status to OFF.

To exit the Enable mode, press the UP key with the Enable code displayed in the lower display and the upper display blank.

STEP	DESCRIPTION	CODE	DISPLAY SETTINGS	AVAILABLE SETTING	FACTORY
1	Program Mode		EPro	ON/OFF	ON
2	Tune Mode		Etun	ON/OFF	ON
3	Setpoint Changes		ESPC	ON/OFF	ON

TABLE 3-2 PROGRAMMODE

To enter the Program mode, press and release the SCROLL key until "Prog" is displayed. Use the DOWN key to enter the Program mode. Depress and release the SCROLL key to sequence through the parameters and their values, alternately showing the parameter code in the lower display with the upper display blank, then the parameter code with the parameter value displayed. Use the UP and DOWN keys to adjust the parameter values. After adjusting a parameter, the upper display will flash, indicating that the new setting has yet to be confirmed. When the setting is as required, it may be confirmed by pressing the AUTO/MANUAL key and the upper display stops flashing. After confirming a change, press the SCROLL key to proceed to the next parameter. Use the DOWN key to advance to the next parameter when a parameter code is showing in the lower display and the upper display is blank.

To exit the Program mode, press the UP key whenever a parameter code is displayed in the lower display and the upper display is blank.

DEFAULT PARAMETER INDICATION

If a parameter value, such as Input Select, was changed while in the Program mode, when returning to the Control mode, a decimal point after each digit will be lit. This display indicates all Tune mode parameters have been set to their default condition. To clear this condition, enter the Tune mode and make a parameter value change and review each parameter for its proper setting.

STEP	DESCRIPTION	CODE	DISPLAY SETTINGS	AVAILABLE SETTING	FACTORY
1	Input Select		inPS	See App. D*	1420
2	Output 1 Action		Out1	Reverse Direct	REV
3	Alarm 1 Type (Output 3 position)		ALA1	P_hi =Proc High nonE=No Alarm bAnd=Band dE =Deviation P_Lo=Proc Low	P_hi
4	Alarm 2 Type (Output 2 position)		ALA2	Same selection as ALA1	nonE
5	Output 2 Usage		USE2	Out2 =Control (action opposite of Out1) LP_r =Loop Reverse LP_d=Loop Direct Ad_r =Rev Logic AND Ad_d=Dir Logic AND Or_r =Rev Logic OR Or_d =Dir Logic OR A2_r =Alm Rev A2_d=Alm Dir	Out2
6	Output 3 Usage		USE3	Al_d =Alm Dir rEcP =Rcdr Out P.V. rEcS =Rcdr Out S.P. LP_r =Loop Reverse LP_d=Loop Direct Ad_r =Rev Logic AND Ad_d=Dir Logic AND Or_r =Rev Logic OR Or_d=Dir Logic OR Al_r =Alm Rev	Al_d
7	Com Bit Rate		CbS	1200, 2400, 4800, 9600	4800

STEP	DESCRIPTION	DISPLAY CODE	AVAILABLE SETTINGS	FACTORY SETTING
8	Com Address	CAd	1 - 32	1
9	CJC Enable	CJC	EnAb diSA	EnAb

* The Hardware Definition Code and input jumper configuration may need to be changed. See Appendix B and C.

TABLE 3-3 TUNEMODE

To enter the Tune mode, press and release the SCROLL key until tunE is displayed. Use the DOWN key to enter the Tune mode. Depress and release the SCROLL key to sequence through the parameters and their values, alternately showing the parameter code in the lower display with the upper display blank, then the parameter code with the parameter value displayed. Use the UP and DOWN keys to adjust the parameter values. After adjusting a parameter, depress the SCROLL key to proceed to the next parameter. Use the DOWN key to advance to the next parameter when a parameter code is showing in the lower display and the upper display is blank.

To exit the Tune mode, press the UP key whenever a parameter code is displayed in the lower display and the upper display is blank.

1	Ramping Setpoint Value	SPrP	± Setpoint Limits	Read Only
2	Setpoint Ramp Rate	SPrr	1 to 9999 units/hour and OFF	OFF
3	Input Filter	Filt	0.0 to 100.0 seconds in .5 sec. increments	2.0
4	Input Correct	iCor	± Span	0
5	Output 1%	Po1	0 to 100%	Read Only

(Continued on next page)

STEP	DESCRIPTION	DISPLAY CODE	AVAILABLE SETTINGS	FACTORY SETTING
6	Output 2%	Po2	0 to 100%	Read Only
7	1st Output Prop. Band	Pb1	0 to 999.9% of Input Span 0%=On/OFF	5.0
8	2nd Output Prop. Band	Pb2	0 to 999.9% of Input Span 0%=ON/OFF	5.0
9	Automatic Reset	ArSt	OFF to 99 mins. 59 secs	OFF
10	Rate	rAtE	0 sec to 99 mins. 59 secs.	0 secs.
11	Overlap/ Deadband	SPrd	-20 to 20% of Pb1 and Pb2	0%
12	Manual Reset	rSEt	0 to 100% Output 1 -100 to 100% Out 2	25%
13	Hysteresis Output 1 Output 2 Out 1 & Out 2 (Alarm hysteresis is fixed at 2 deg.)	HyS1 HyS2 HySt	0.1 to 10.0% of span 0.1 to 10.0% of span 0.1 to 10.0% of span	0.5 0.5 0.5
14	Setpoint Upper Limit	SPuL	Span Max.	Span Max.
15	Setpoint Lower Limit	SPLL	Span Min.	Span Min.
16	Process Output Upper	Pou	-1999 to 9999	Span Max.

STEP	DESCRIPTION	DISPLAY CODE	AVAILABLE SETTINGS	FACTORY SETTING
17	Process Output Lower	PoL	-1999 to 9999	Span. Min.
18	Output 1 % Limit	o1PL	0 to 100%	100
19	Output 1 Cycle Time	Ct1	.5, 1, 2, 4, 8, 16, 32, 64, 128, 256, 512 secs	32
20	Output 2 Cycle Time	Ct2	.5, 1, 2, 4, 8, 16, 32, 64, 128, 256, 512 secs	32
21	Process High Alarm 1	PHA1	± Span	Span Max.
22	Process Low Alarm 1	PLA1	± Span	Span Min.
23	Band Alarm 1	bAL1	0 to Span	5
24	Deviation Alarm 1	dAL1	± Span	5
25	Process High Alarm 2	PHA2	± Span	Span Max.
26	Process Low Alarm 2	PLA2	± Span	Span Min.
27	Band Alarm 2	bAL2	0 to Span	5
28	Deviation Alarm 2	dAL2	± Span	5

STEP	DESCRIPTION	DISPLAY CODE	AVAILABLE SETTINGS	FACTORY SETTING
29	Loop Alarm Enable	LAEn	0=Disable 1=Enable	0
30	Loop Alarm Time	LAti	1 sec to 99 mins. 59 secs.	99 mins. 59 secs.
31	Decimal Position	dPoS	0, 1, 2, 3 (Linear Input Only)	1
32	Engineering Units Upper	Euu	-1999 to 9999	1000
33	Engineering Units Lower	EuL	-1999 to 9999	0
34	*Enable Pre Tune	EPtn	0=Disable 1=Enable	0
35	Enable Manual Control	ESby	0=Disable 1=Enable	0
36	**Setpoint Ramp Rate Enable	ESPr	0=Disable 1=Enable	0
37	Comm. Enable	CCon	0=Disable 1=Enable	1

* Activates Pre-Tune on power-up when enabled.

** When enabled, allows user to change ramp rate without having to enter Tune mode.

Note: Pre-Tune and Auto-Tune Modes will not function if OUTPUT 2 has been configured as ON/OFF.

Pre-Tune Mode 3.3

The Pre-Tune mode may be used to set the instrument's PID parameters to values which are approximately correct, in order to provide a base from which the Auto Tune mode may optimize tuning.

To engage the Pre-Tune mode, with the instrument in Control mode, press and hold the UP and DOWN keys for approximately 5 seconds (the display will flash during this period) until the AT LED flashes once. Release the UP and DOWN keys. Press and hold the SCROLL key for approximately 3 seconds until the AT LED flashes.

To disengage the Pre-Tune mode, press and hold the UP and DOWN keys until the AT LED flashes once. Release the UP and DOWN keys. Press and hold the SCROLL key for approximately 3 seconds until the AT LED is continuously OFF.

Note: Since the Pre-Tune mode is a single-shot operation, it will automatically disengage itself once the operation is complete. If the Enable Pre-Tune parameter in the Tune mode is enabled, then on power-up, the unit will automatically engage the Pre-Tune and remain in Pre-Tune until the operation is complete.

Also note: The Pre-Tune mode will not engage during setpoint ramping. Additionally, if the process variable is within 5% of input span from the setpoint, or if an incorrect key sequence is used, the Pre-Tune mode will not be engaged.

Auto-Tune Mode 3.4

The Auto-Tune mode is used to optimize tuning while the instrument is operating.

To engage the Auto-Tune mode, with the instrument in Control mode, press and hold the UP and DOWN keys for approximately 5 seconds (the display will flash during this period) until the AT LED flashes once. Release the UP and DOWN keys. Press and hold the AUTO/MAN key for approximately 3 seconds until the AT LED lights continuously.

If the Enable Pre-Tune parameter in the Tune mode is enabled, then a power interruption, the unit will first engage the Pre-Tune mode prior to engaging the Auto-Tune mode when power is restored.

To disengage the Auto-Tune mode, press and hold the UP and DOWN keys until the AT LED flashes once. Release the UP and DOWN keys. Press and hold the AUTO/MAN key for approximately 3 seconds until the AT LED is continuously OFF.

How Auto-Tune Works

This instrument uses a pattern recognition algorithm, which monitors the process error (deviation signal). Figure 3-1 shows a typical temperature application-involving process start up, a setpoint change and a load disturbance. The deviation signal is shown shaded and overshoots have been exaggerated for clarity.

The auto-tuning algorithm observes once complete deviation oscillation before calculating a set of PID values. Successive deviation oscillations cause values to be recalculated so that the controller rapidly converges on optimal control.

When the auto-tuning controllers are switched off, the final PID terms remain stored in the controller's nonvolatile memory, and are used as starting values at the next switch on.

The stored values are not always valid, if for instance, the controller is brand new or the application has been changed. In these cases the user can utilize an extra facility on the auto-tuning controllers called "Pre-Tune". Figure 3-2 shows how the "Pre-Tune" facility artificially disturbs the start-up pattern so that a first approximation of the PID values can be made prior to the setpoint being reached.

New instruments supplied by the factory contain PID terms set at "default" values which have been found to give adequate and safe control over a wide range of applications. In the "Pre-Tune" mode of operation, the "default" PID terms are loaded and the controller demands 100% power until the process value has moved approximately halfway to the setpoint. At that point, power is removed thereby introducing a deviation oscillation.

Once the oscillation peak has passed, the pre-tune algorithm can calculate its first approximation to the optimum PID values. The power is reapplied using the new values. This technique limits the possibility of setpoint overshoot when the instrument is new or the application has been changed.

FIGURE3-1

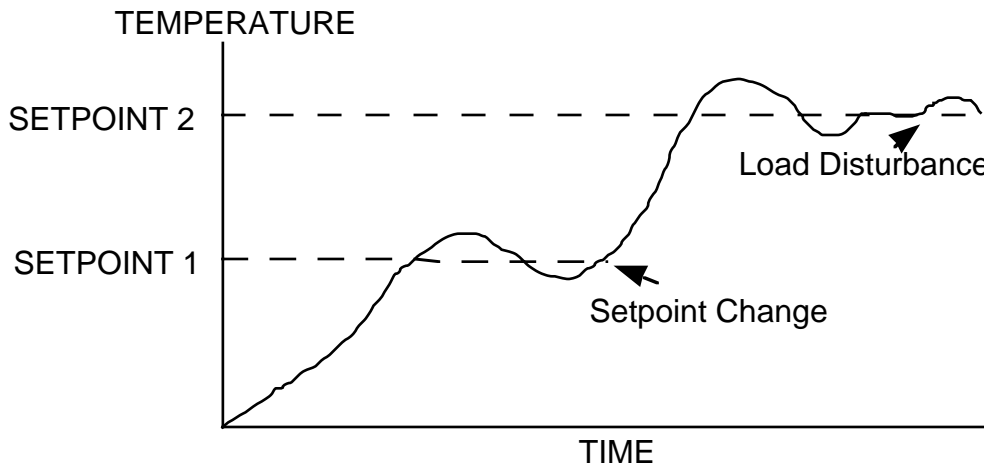
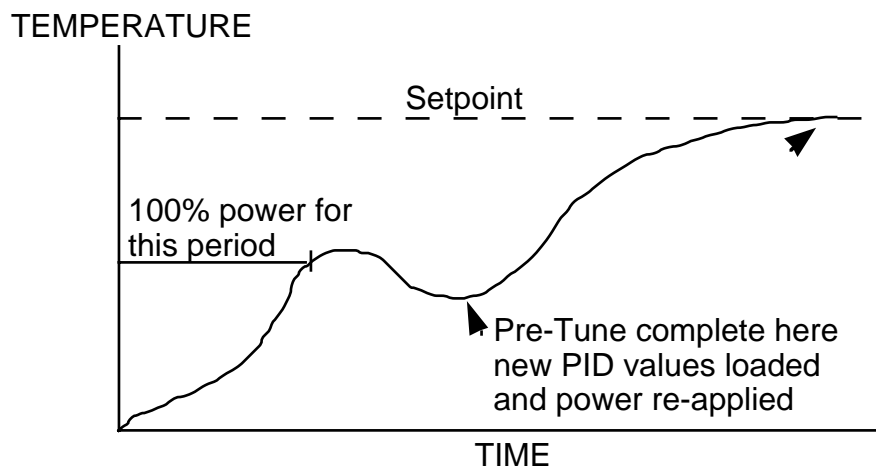

FIGURE3-2



Manual Tuning Method 3.5

1. Cycle Time - Time Proportioning Outputs
 - A. Adjusting the cycle time affects instrument operation
 1. Shorter Cycle Time
 - a. More accurate control
 - b. Shorter life span of electromechanical components
2. Proportional Bandwidth
 - A. Proportional Bandwidth is the inverse of gain.
Increased Bandwidth = Decreased Gain
 - B. Increase the Proportional Bandwidth if:
 1. The process overshoots excessively
 2. The process oscillates excessively
 - C. Decrease the Proportional Bandwidth if:
 1. The process responds slowly
 2. The process fails to reach setpoint
3. Add Automatic Reset
 - A. Increase the Automatic Reset until the process becomes unstable, then decrease until stability is restored.
 - B. Be sure to allow sufficient time for the process and the instrument to react.
4. Rate Adjustment
 - A. Rate can cause process instability. Typically add Rate as 1/10 th of the automatic reset value.
 - B. Decrease Rate if:
 1. The process overshoots/undershoots
 2. If the process oscillates excessively
5. Manual Reset
 - A. After making all other adjustments, use if an offset exists between the setpoint and the process variable.
 - B. If the process is:
 1. Below setpoint use a positive Manual Reset value
 2. Above the setpoint use a negative Manual Reset value

Control Capability 4.1

A variety of user programmable control features and capabilities are available including:

- Auto Tune
- Time Proportioning Control
- Alarm Functions
- Auto/Manual Switching
- Process Retransmission
- Setpoint Retransmission
- On-Off Control
- Current Proportioning
- Dual Output Control
- Setpoint Adjustment
- Setpoint Ramp Rate

The capabilities available in a specific unit are dependent upon the hardware options specified when the instrument is ordered. Refer to Appendix F for the decoding of the instrument model number. Current proportioning control cannot be implemented if a current output was not ordered. The available output types and quantity of each are as follows:

<u>Type of Output</u>	<u>Quantity Available</u>
• SPDT mechanical relay output	Up to three
• SSR Driver	Up to three
• mADC current output	Up to two

Control Responses 4.2

Each instrument may be configured to provide 3 mode proportional control. Proportional control is provided with Proportional Band, Integration, and Derivative responses. The PID parameters are defined as follows:

		<u>Out 1</u>	<u>Out2</u>
P (Proportional)	Proportional Band	Pb1	Pb2
I (Integration)	Automatic Reset	ArSt	ArSt
D (Derivative)	Rate	rAtE	rAtE

Manual Reset is provided for use in lieu of, or in conjunction with automatic reset. A cycle time adjustment parameter is provided for use with each time proportioning control output.

Direct/Reverse Operation of Outputs 4.3

Direct operation is typically used with cooling applications. On-Off direct output(s) will turn on when the process variable exceeds setpoint. Proportional direct output(s) will increase the percentage of output as the process value increases within the proportional band.

Reverse operation is typically used with heating applications. On-Off reverse output(s) will turn off when the process variable exceeds setpoint. Proportional reverse output(s) will decrease the percentage of output as the process value increases within the proportional band.

Output 2 will be Direct when Output 1 is selected as Reverse and Reverse when Output 1 is selected as Direct.

On-Off Control 4.4

On-Off control can be implemented with SPDT relay or SSR driver output(s) by setting the corresponding proportional band (Pb) to 0.0. On-Off operation can be assigned to Output 1 only (Output 2 not present), Output 1 **AND** Output 2, or Output 2 only (Output 1 is time proportional or current proportional). A hysteresis adjustment is provided for On-Off outputs, "HyS1" for Output 1 only, "HyS2" for Output 2 only, or "HySt" for Output 1 **AND** 2. This adjustment is in % of input span and defines the bandwidth of the hysteresis. Relay chatter can be eliminated by proper adjustment of this parameter. When operating in On-Off control, the output(s) will turn on or off depending upon the setpoint, the process value, and the hysteresis adjustment.

Time Proportioning Control 4.5

Time Proportioning control can be implemented with a SPDT relay or SSR driver. Time proportioning control can be selected for either Output 1 or Output 1 and Output 2, depending on hardware configuration. Time proportioning control is accomplished by cycling the output on and off during a prescribed period of time when the process variable is within the proportional band.

Ex: Calculated output % = 40%; Cycle time adjustment = 32 seconds
Output on time = $.4 \times 32 = 12.8$ seconds
Output off time = $.6 \times 32 = 19.2$ seconds

When the unit is operating in the Control mode, the control algorithm determines the output % required to correct for any difference between the process value and the setpoint. The output calculation is affected by Tune mode parameter adjustments. See Figure 4-1 (below) for proportional bandwidth effect on the output.

Current Proportioning Control 4.6

Current Proportioning control can be implemented on units provided with mADC current output(s). Current Proportioning control provides a 4 to 20mADC or 0-20mADC output in response to process value and setpoint. As with Time proportioning, the calculated output % for Current proportioning is affected by the Tune mode parameter adjustments.

See Figure 4-1 (below) for proportional bandwidth effect on the output.

FIGURE 4-1

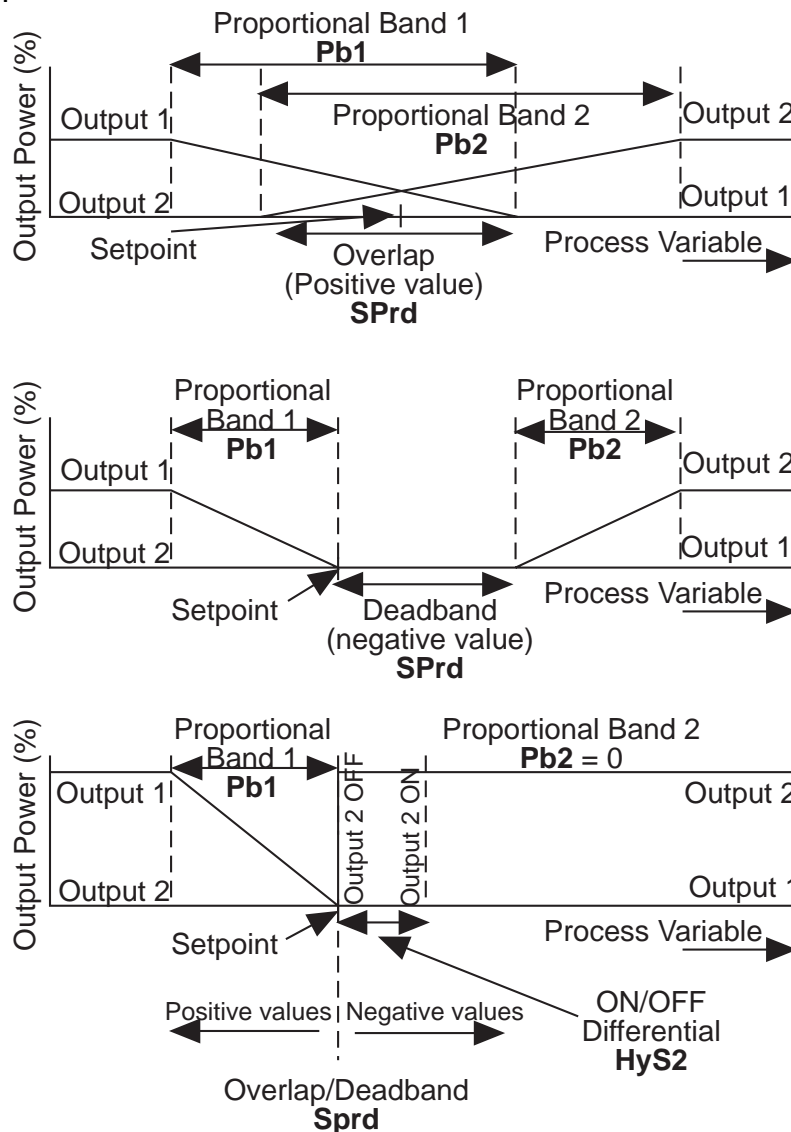

Setpoint Adjustment 4.7

To adjust the setpoint with the instrument in the Control mode, press the UP key to raise the setpoint and the DOWN key to lower the setpoint.

Depressing the SCROLL key, if setpoint ramping is enabled and if ramp rate is not OFF will change the displays to:

Upper Display = Ramping Setpoint Value (Read Only)

Lower Display = SPPrP

Appendix A

Glossary of Terms

Input Filter Time Constant

This parameter is used to filter out any extraneous impulses on the process variable. This filtered PV is used for all PV-dependent functions (control, alarm, etc). The time constant is adjustable from 0.0 seconds (off) to 100.0 seconds, in 0.5 second increments. Default value is 2.0 seconds. Display code is FiLt.

Input Correction

This parameter is used to modify the actual process variable and is adjustable in the range \pm input span. Default value is 0. Display code is iCor.

Proportional Band 1

This parameter is the portion of the input span over which the Output 1 power level is proportional to the displayed process variable value. It may be adjusted in the range 0.0% (ON/OFF) to 999.9%. Default value is 5.0%. Display code is Pb1. The function is illustrated in Figure A-1, page 49.

Proportional Band 2

This parameter is the portion of the input span over which the Output 2 power level is proportional to the displayed process variable value. It may be adjusted in the range 0.0% (ON/OFF) to 999.9%. Default value is 5.0%. Display code is Pb2. In Figure A-1 (page 49), Proportional Band 2 is shown (a) with a nonzero value (Case 1 and Case 2) - PID Control, and (b) with a zero value (Case 3) - ON-OFF control.

Automatic Reset (Integral)

This parameter is used to bias the proportional output(s) to compensate for process load variations. It is adjustable in the range 1 second to 99 minutes 59 seconds per repeat and OFF (value greater than 99 minutes 59 seconds). Decreasing the time increases the Reset. This parameter is not available if Pb1 is set to 0. Default value is OFF. Display code is ArSt.

Rate (Derivative)

This parameter is adjustable in the range 00 seconds to 99 minutes 59 seconds and specifies how the control action responds to the rate of change in the process variable. This parameter is not available if Pb1 is set to 0. Default value is 0.0. Display code is rAtE.

Overlap/Deadband

This parameter defines the portion of the proportional band (Pb1 + Pb2) over which both outputs are active (or, in the case of a deadband, neither output is active). It is adjustable in the range -20% to +20% (negative value = deadband). The function is illustrated in Figure A-1, page 49. This parameter is not applicable if Pb1 = 0 or if there is no Output 2. Default value is 0%. Display code is SPrd.

Note: With Output 2 set on ON/OFF (Figure A-1, page 49, Case 3) the Overlap/Deadband parameter has the effect of moving the ON hysteresis band of Output 2 to create an overlap (positive values) or a deadband (negative values). When Overlap/Deadband = 0, the Output 2 OFF edge of the Output 2 ON/OFF hysteresis band coincides with the point at which Output 1 = 0%.

Manual Reset

This parameter is expressed as a percentage of output power and is adjustable in the range 0% to 100% (if only Output 1) or -100% to +100% (if both Output 1 and Output 2). This parameter is not applicable if Pb1 = 0. Default value is 25%. Display code is rSEt.

Hysteresis

This parameter is a switching differential used when one or both outputs have been set to ON/OFF. This parameter is adjustable within the range 0.1% to 10.0% of input span. Default value is 0.5%. Display code is HyS1, HyS2, HySt. Note: Alarm output hysteresis is fixed at 2°C/F.

Setpoint Upper Limit

This parameter is the maximum limit for setpoint adjustment. It should be set to a value which prevents the setpoint being given a value which will cause damage to the process. The range of adjustment is to Maximum Input Range. Default value is Range Maximum. Display code is SPuL.

Setpoint Lower Limit

This parameter is the minimum limit for setpoint adjustment. It should be set to a value which prevents the setpoint being given a value which will cause damage to the process. The range of adjustment is to Minimum Input Range. Default value is Range Minimum. Display code is SPL.

Process Output Upper Value

This parameter defines the value of the retransmitted output (process variable or setpoint, whichever is applicable) at its maximum value; for example, for a 0-5V output, this value corresponds to 5V. It may be adjusted within the range -1999 to 9999. The decimal position is always the same as that for the process variable input. Default value is Input Range Maximum. Display code is Pou.

Note: If this parameter is set to a value less than that for the Process Output Lower Value, the relationship between the process variable/setpoint value and the retransmission output is reversed.

Process Output Lower Value

This parameter defines the value of the retransmitted output (process variable or setpoint, whichever is applicable) at its minimum value; for example, for a 0-5V output, this value corresponds to 0 V. It may be adjusted within the range -1999 to 9999. The decimal position is always the same as that for the process variable input. Default value is Input Range Minimum. Display code is PoL.

Note: If this parameter is set to a value greater than that for the Process Output Upper Value, the relationship between the process variable/setpoint value and the retransmission output is reversed.

Output 1 Percent Limit

This parameter is used to limit the power level of Output 1 and may be used to protect the process being controlled. It may be adjusted between 0 % and 100%. This parameter is not applicable if Pb1 = 0. Display code is o1PL.

Cycle Time

This parameter is used to select the on/off cycle time for time proportioning outputs (Ct1 for Output 1 and Ct2 for Output 2). The permitted range of value is 0.5, 1, 2, 4, 8, 16, 32, 64, 128, 256, or 512 seconds. Default value is 32. Display codes Ct1 & Ct2.

Process High Alarm 1 Value

This parameter, applicable only when Alarm 1 is selected to be a Process High alarm, defines the process variable value at or above which Alarm 1 will be active. Its value may be adjusted between Input Range Maximum and Input Range Minimum. Its default value is Input Range Maximum. Display code is PHA1.

Process Low Alarm 1 Value

This parameter, applicable only when Alarm 1 is selected to be a Process Low alarm, defines the process variable value at or below which Alarm 1 will be active. Its value may be adjusted between Input Range Maximum and Input Range Minimum. Its default value is Input Range Minimum. Display code is PLA1.

Band Alarm 1 Value

This parameter, applicable only if Alarm 1 is selected to be a Band Alarm, defines a band of process variable values, centered on the setpoint value. If the process variable value is outside this band, the alarm will be active. This parameter may be adjusted from 0 to span from the setpoint. The default value is 5. The display code is bAL1.

Deviation Alarm 1 Value

This parameter, applicable only if Alarm 1 is selected to be a Deviation High/Low Alarm, defines a value above (positive value - Deviation High Alarm) or below (negative value - Deviation Low Alarm) the setpoint; if the process variable deviates from the setpoint by a margin greater than that defined by this parameter, Alarm 1 goes active. This parameter may be adjusted in the range \pm span from setpoint. The default value is 5. Display code is dAL1.

Process High Alarm 2 Value

This parameter, applicable only when Alarm 2 is selected to be a Process High Alarm, defines the process variable value at or above which Alarm 2 will be active. Its value may be adjusted between Input Range Maximum and Input Range Minimum. Its default value is Input Range Maximum. Display code is PHA2.

Process Low Alarm 2 Value

This parameter, applicable only when Alarm 2 is selected to be a Process Low Alarm, defines the process variable value at or below which Alarm 2 will be active. Its value may be adjusted between Input Range Maximum and Input Range Minimum. Its default value is Input Range Minimum. Display code is PLA2.

Band Alarm 2 Value

This parameter, applicable only if Alarm 2 is selected to be a Band Alarm, defines a band of process variable values, centered on the setpoint value. If the process variable is outside this band, the alarm will be active. This parameter may be adjusted from 0 to span from the setpoint. The default value is 5. Display code is bAL2.

Deviation Alarm 2 Value

This parameter, applicable only if Alarm 2 is selected to be a Deviation High/Low Alarm, defines a value above (positive value - Deviation High Alarm) or below (negative value - Deviation Low Alarm) the setpoint; if the process variable deviates from the setpoint by a margin greater than that defined by this parameter, Alarm 2 goes active. This parameter may be adjusted in the range \pm span from setpoint. The default value is 5. Display code is dAL2.

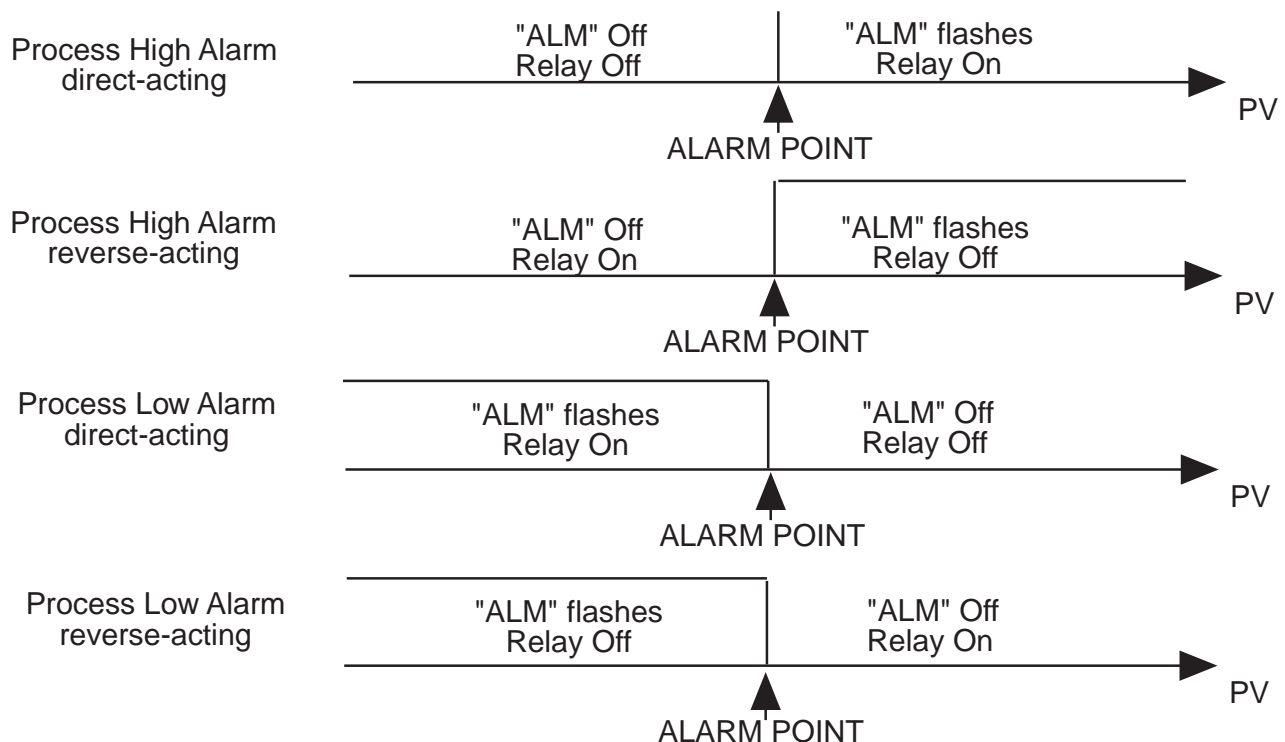

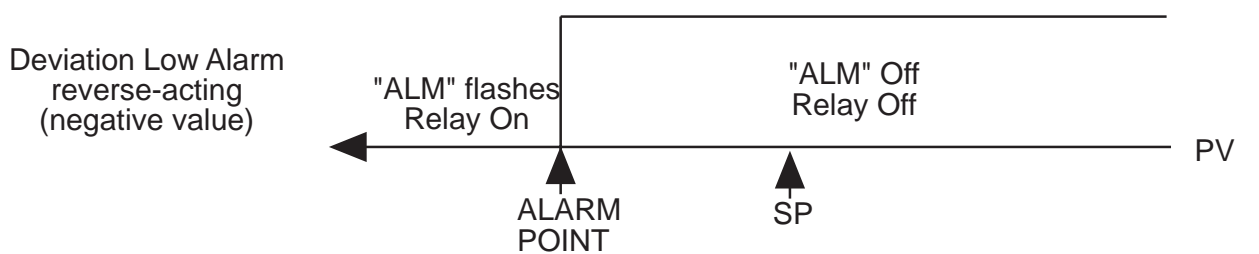
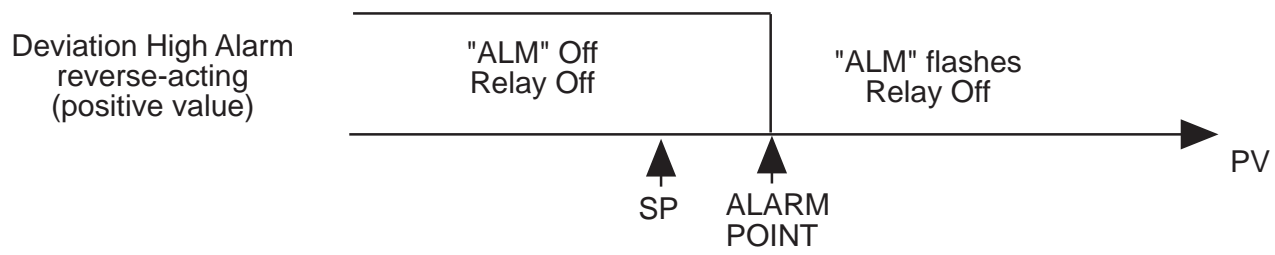
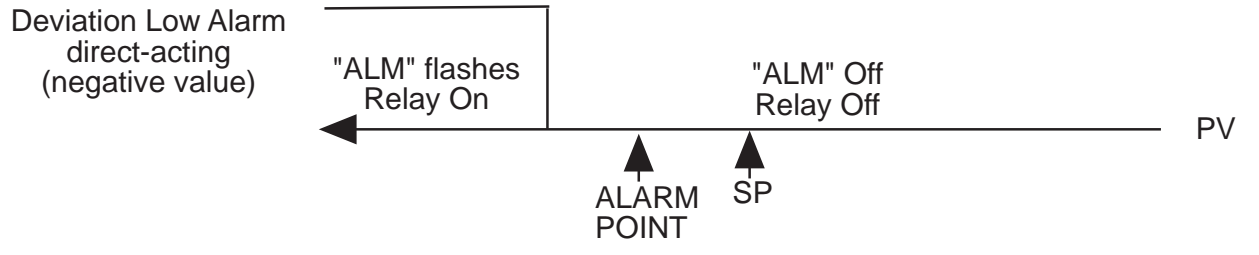
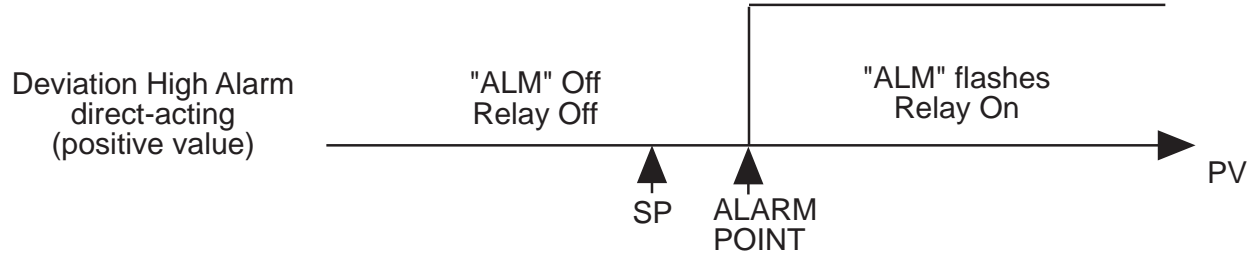
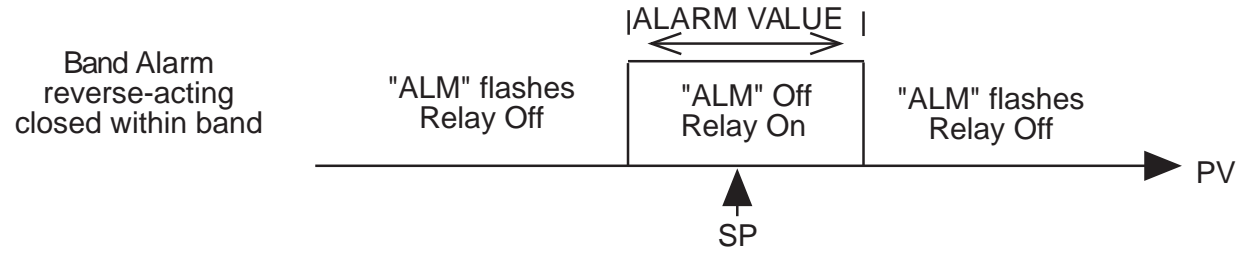
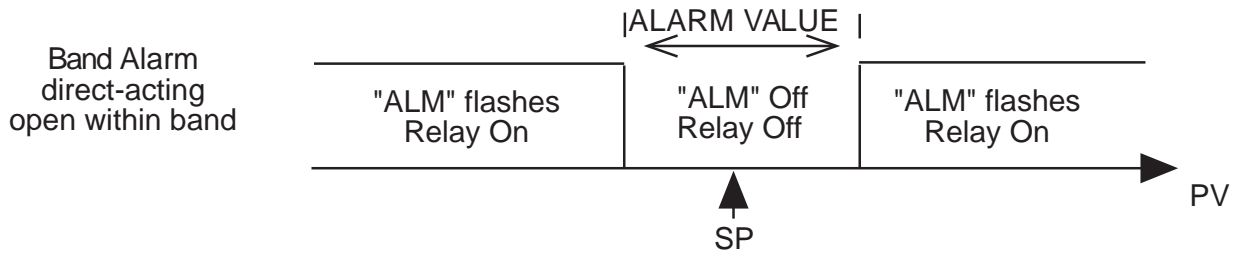

Loop Alarm Enable

This parameter is the means by which the user can enable or disable the Loop Alarm. The Loop Alarm is a special alarm which detects faults in the control feedback loop by continuously monitoring process variable response to the control output(s).

To configure the loop alarm, proceed as follows:

Program - ALA1=nonE, ALA2=nonE, USE3=LP_r-when active ALM LED flashes and Output 3 is OFF.

Program - ALA1=nonE, ALA2=nonE, USE3=LP_d-when ALM LED flashes and Output 3 is ON.

The Loop Alarm, when enabled, repeatedly checks the control output(s) for being at the maximum or minimum limit. If an output is found to be at the limit, the Loop Alarm mode starts a timer; thereafter, if the high output has not caused the process variable to be corrected by a predetermined amount V after a time T has elapsed, the Loop Alarm goes active. Subsequently, the Loop Alarm mode repeatedly checks the process variable and the control output(s). When the process variable starts to change value in the correct sense or when the output comes below the limit, the Loop Alarm is deactivated.

For PID control, the Loop Alarm Time T is always set to twice the value of the Auto Reset parameter. For ON/OFF control, the user defined value of the Loop Alarm Time Set Up parameter is used.

The value of V is dependent upon the input type:

Deg C: 2°C or 2.0°C

Deg F: 3°F or 3.0°F

Linear Range: 10 least significant display units

For single output instruments, the limits are 0% and Out 1 Max %. For dual output instruments, the limits are -100% and Out 1 Max %.

Notes:

1. Correct operation of the Loop Alarm depends upon reasonably accurate PID tuning. (Continued on next page)

2. The Loop Alarm is automatically disabled during Manual Control mode and during execution of the Pre-Tune mode. Upon exit from Manual mode or after completion of the Pre-Tune routine, the Loop Alarm is automatically re-enabled.

Loop Alarm Time

When full ON/OFF control is selected and Loop Alarm is enabled, this parameter determines the duration of the limit condition after which the Loop Alarm will be activated. It may be adjusted within the range of 1 second to 99 minutes 59 seconds. This parameter is omitted from the Tune mode display sequence if ON/OFF control is not selected or Loop Alarm is disabled. The default setting 99:59. Display code is LAti.

Logical Combination of Alarms

Two alarms may be combined logically to create an AND/OR situation. They may be configured for Reverse-acting or Direct-acting. Either Output 2 or Output 3 may be assigned as Logical Outputs.

Example:

Logical OR of Alarm 1 with Alarm 2

Direct-Acting

AL1 OFF, AL2 OFF: Relay OFF
AL1 ON, AL2 OFF: Relay ON
AL1 OFF, AL2 ON: Relay ON
AL1 ON, AL2 ON: Relay ON

Reverse-Acting

AL1 OFF, AL2 OFF: Relay ON
AL1 ON, AL2 OFF: Relay OFF
AL1 OFF, AL2 ON: Relay OFF
AL1 ON, AL2 ON: Relay OFF

Logical AND of Alarm 1 with Alarm 2

Direct-Acting

AL1 OFF, AL2 OFF: Relay OFF
AL1 ON, AL2 OFF: Relay OFF
AL1 OFF, AL2 ON: Relay OFF
AL1 ON, AL2 ON: Relay ON

Reverse-Acting

AL1 OFF, AL2 OFF: Relay ON
AL1 ON, AL2 OFF: Relay ON
AL1 OFF, AL2 ON: Relay ON
AL1 ON, AL2 ON: Relay OFF

ASYMMETRICAL BAND ALARM

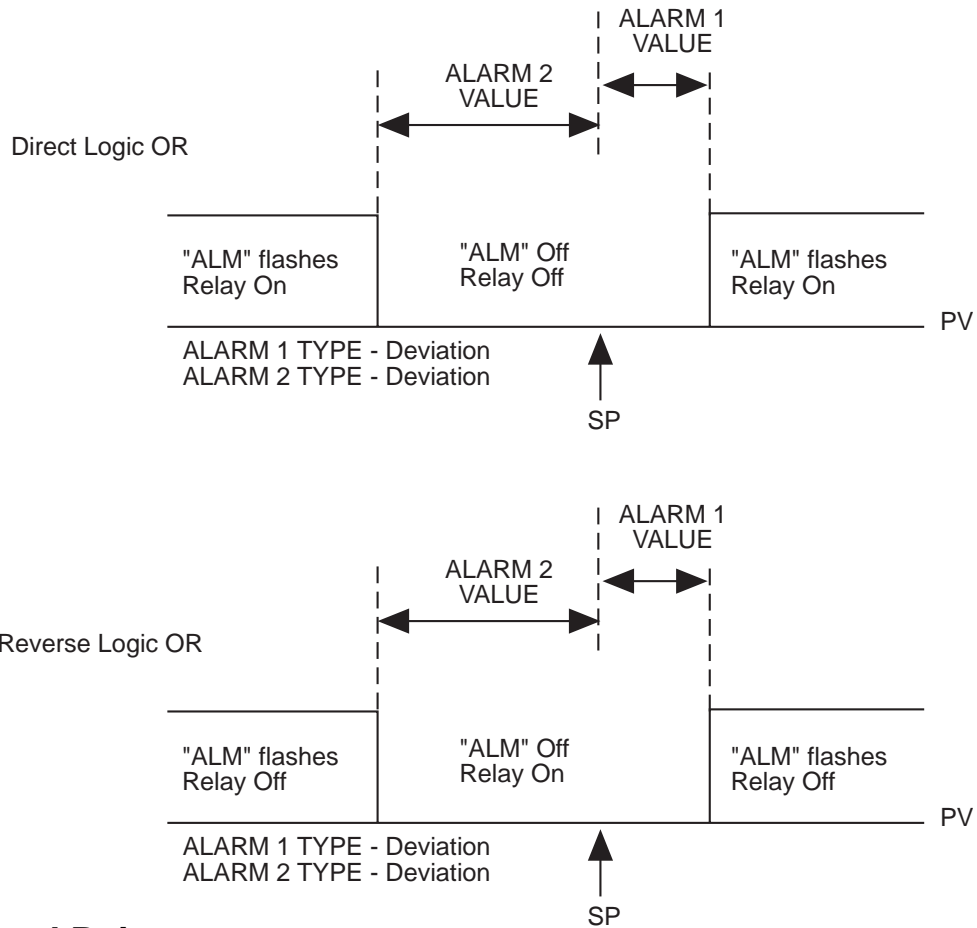

Decimal Point

This parameter, applicable only if a linear input is specified, defines the position of the decimal point in values for the process variable, setpoint, alarm levels and retransmission outputs as follows:

Value	Decimal Point Position
0	XXXX
1	XXX.X
2	XX.XX
3	X.XXX

The default value is 0. Display code is dPoS.

Engineering Units Upper

This parameter, applicable only if a linear input is specified, defines the scaled input value when the process variable input is at its maximum value. It is adjustable between -1999 to 9999. The default value is 1000. This parameter can be set to a value less than (but not equal to) Engineering Units Lower, in which case the sense of the input is reversed. Display code is Euu.

Engineering Units Lower

This parameter, applicable only if a linear input is specified, defines the scaled input value when the process variable input is at its minimum value. It is adjustable between -1999 and 9999. The default value is 0. This parameter can be set to a value greater than (but not equal to) Engineering Units Upper, in which case the sense of the input is reversed. Display code is EuL.

Pre-Tune Enable/Disable

This parameter determines whether or not the instrument Pre-Tune mode is activated on power up or not (0=disabled, 1=enabled). Default is 0. Display code is EPtn.

Manual Mode Enable/Disable

This parameter determines whether operator selection of manual control is enabled or disabled (0=disabled, 1=enabled). The default setting is 0. Display code is ESby.

Setpoint Ramp Enable/Disable

This parameter enables/disables use of the Setpoint Ramp feature (0=disabled, 1=enabled). The default setting is 0. Display code is ESPr.

Communications Enable

This parameter enables/disables the changing of parameter values via the RS485 communications link, if the Communications option is specified. Settings are 0=disabled and 1=enabled. Default setting is 0. Display code is CCon.

FIGURE A-1
 Proportional Band & Deadband/Overlap

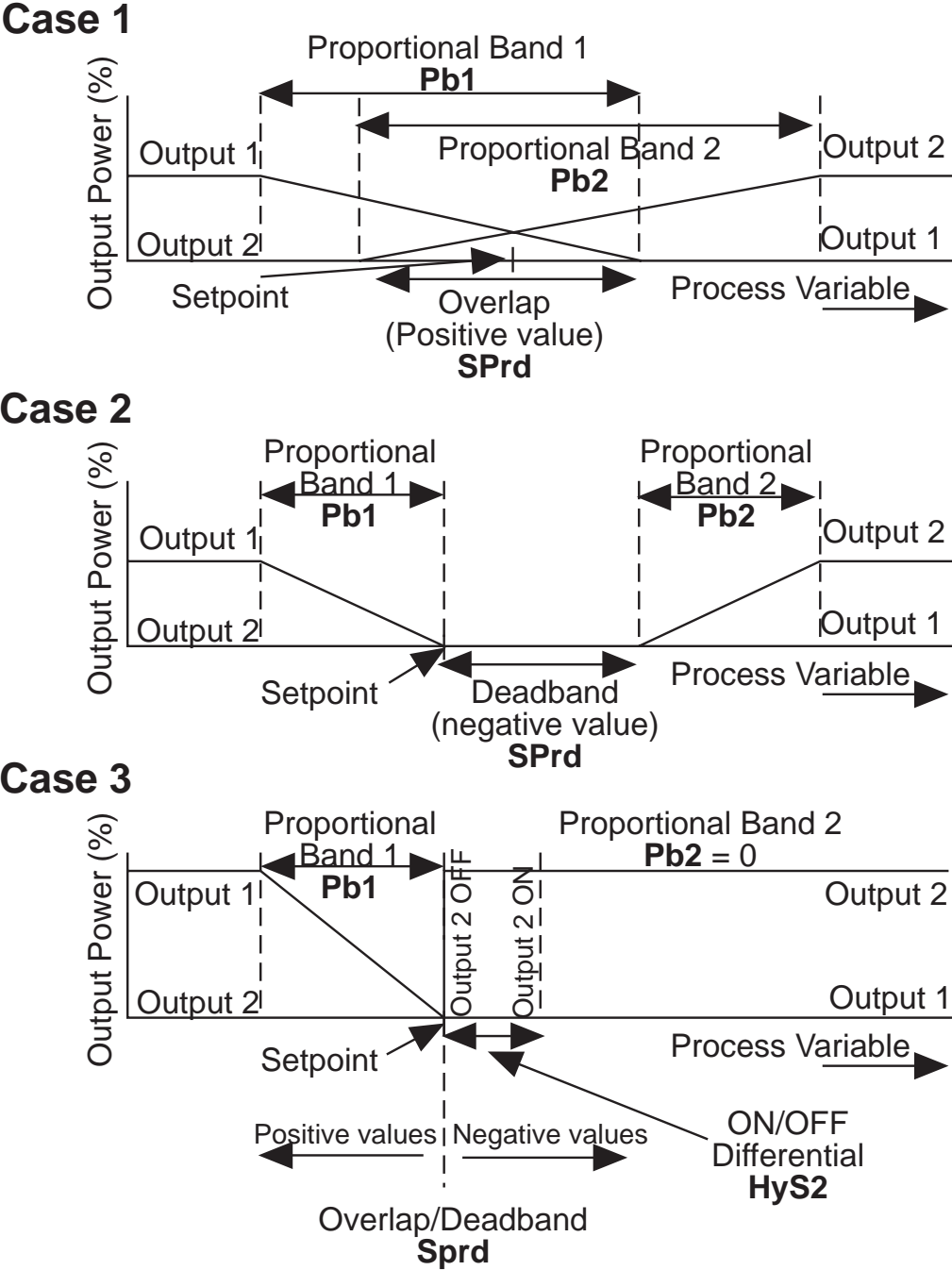

Appendix B

Board Layout - Jumper Positioning

FIGURE B-1 Exploded View & Board Layout

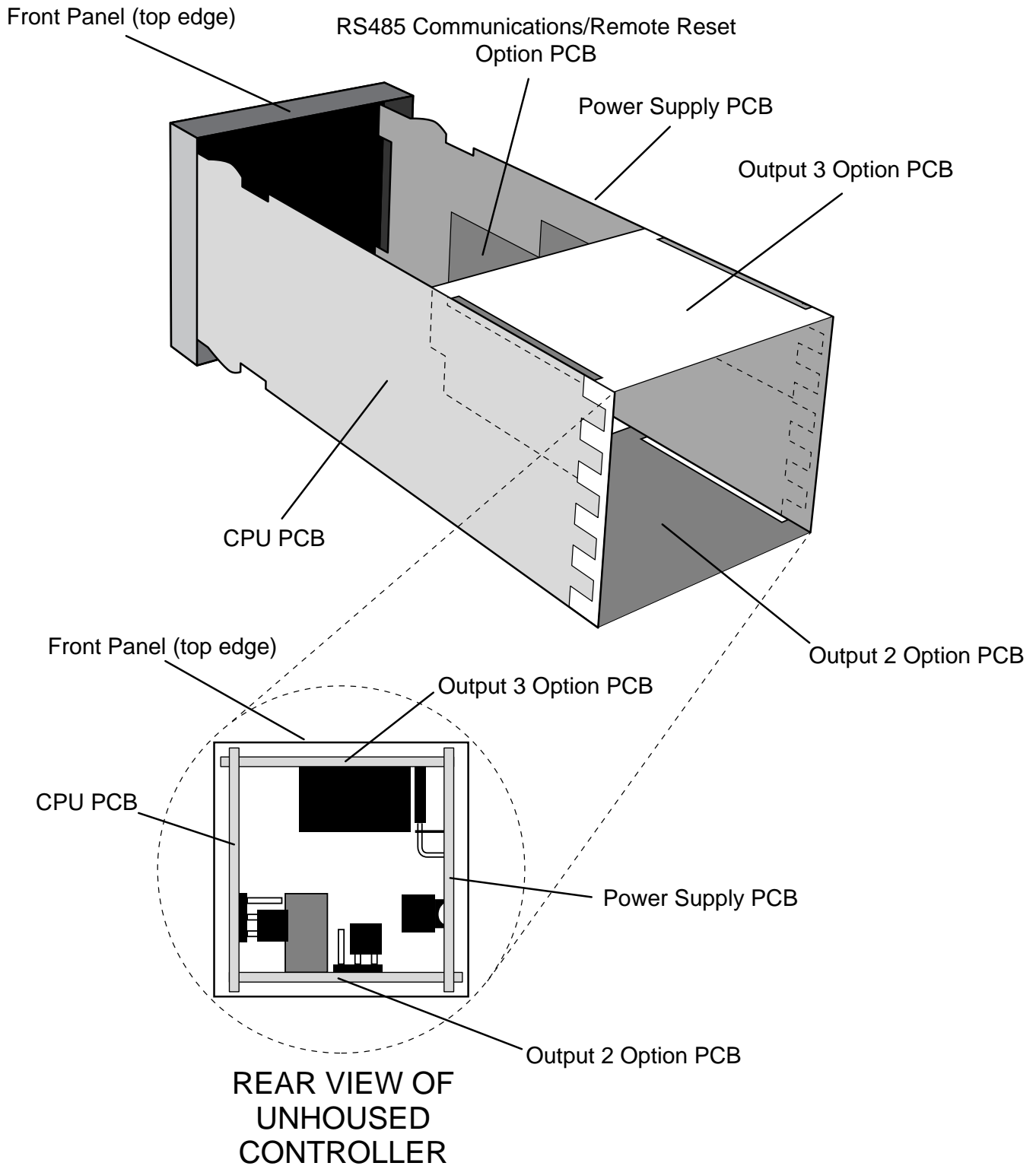
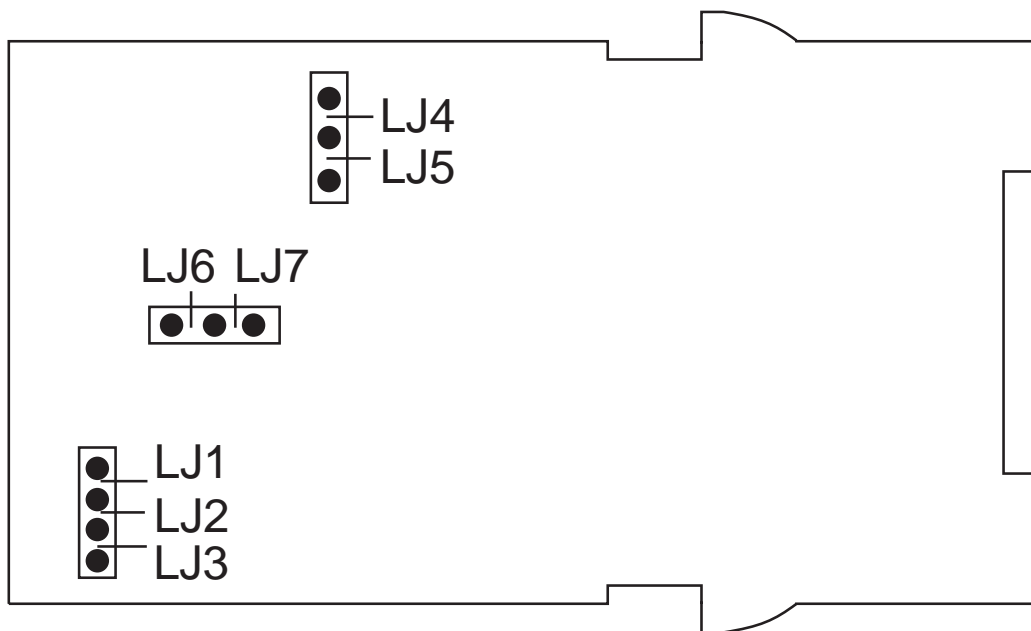

FIGURE B-2 CPU PWA WITH RELAY OR SSR OUTPUT 1



<u>Input Type</u>	<u>LJ1, LJ2, LJ3 Jumper Position</u>	<u>Output Type</u>	<u>LJ4, LJ5 Jumper Position</u>	<u>LJ6, LJ7 Jumper Position</u>
RTD DC (mV)	None Parked	Relay	LJ5	LJ6
T/C	LJ3	SSR	LJ4	LJ7
DC (mA)	LJ2			
DC (V)	LJ1			

FIGURE B-3 CPU PWA WITH DC OUTPUT 1















<u>Input Type</u>	<u>LJ1, LJ2, LJ3 Jumper Position</u>	<u>Output Type</u>	<u>LJ4, LJ5 Jumper Position</u>
RTD DC (mV)	 None Parked	DC (0-100)	 LJ8
T/C	 LJ3	DC (0-20mA)	 LJ9
DC (mA)	 LJ2	DC (0-5V)	 LJ8
DC (V)	 LJ1	DC (4-20mA)	 LJ9

FIGURE B-4 OPTION PWA DC OUTPUT 2/OUTPUT 3

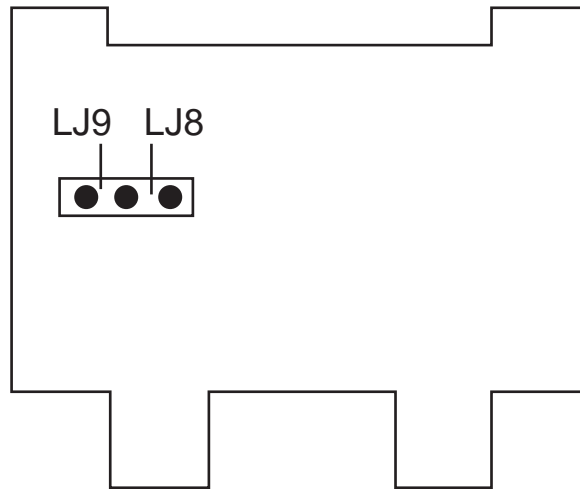

<u>Output Type</u>	<u>LJ8, LJ9 Jumper Position</u>
DC (0-10V)	 LJ8
DC (0-20mA)	 LJ9
DC (0-5V)	 LJ8
DC (4-20mA)	 LJ9

Appendix C

Hardware Definition Code

The Hardware Definition Code is used to represent the hardware installed (input type, Output 1 type, Output 2 type and Output 3 type); this must be compatible with the hardware actually installed. It can be accessed, with the instrument in Program mode, by simultaneously depressing the DOWN and SCROLL keys. The displays will show "XXXX" (where X represents any number) in the upper display and "dEFn" in the lower display, where:

the first (left-most) digit is input type:

- 1=RTD/Linear mV
- 2=Thermocouple
- 3=Linear DC mA
- 4=Linear DC V

the second digit is Output 1 type:

- 1=Relay
- 2=SSR
- 3=DC 0-10V
- 4=DC 0-20mA
- 5=DC 0-5V
- 7=DC 4-20mA

the third digit is Output 2 type:

- 0=Output 2 not installed
- 1=Relay (Control Output 2 OR Alarm 2)
- 2=SSR (Control Output 2 OR Alarm 2)
- 3=DC 0-10V (control only)
- 4=DC 0-20mA (control only)
- 5=DC 0-5V (control only)
- 7=DC 4-20mA (control only)

the fourth digit is Output 3 type:

- 0=Output 3 not installed
- 1=Relay (Alarm 1 only)
- 2=SSR (Alarm 1 only)
- 3=DC 0-10V (retransmit only)
- 4=DC 0-20mA (retransmit only)

5=DC 0-5V (retransmit only)
7=DC 4-20mA (retransmit only)

The displayed code may be incremented/decremented using the UP/DOWN keys as required. The maximum setting available is 4777. For example, the code for a thermocouple input, DC 4-20mA Output 1 and relay Output 3 would be 2701. When the code is first altered, the code display will flash, until the desired value is displayed and confirmed by pressing the Auto/Manual key.

While the Hardware Definition Code is displayed, depressing the SCROLL key will cause the display to change to:

nonE	or	r485
OPtn		OPtn

Where nonE indicates the absence of the communications option and r485 indicates the presence of the communications option.

NOTE: It is essential that this code is changed whenever there is a change to the instrument's hardware configuration (change of input/output type, alarm/retransmit output added/removed etc.). The instrument's software depends upon this code to ensure that the instrument operates correctly.

To exit from the Hardware Definition Code display, depress the DOWN and SCROLL keys simultaneously.

Appendix D

Input Range Codes

The input ranges available (selectable via the front panel) are:

For Thermocouple Inputs

TYPE	INPUT RANGE	DISPLAYED CODE	TYPE	INPUT RANGE	DISPLAYED CODE
R	0 - 1650°C	1127	K	0 - 760°C	1719
R	32 - 3002°F	1128	K	32 - 1400°F	1720
S	0 - 1649°C	1227	K	0 - 1373°C	1723
S	32 - 3000°F	1228	K	32 - 2503°F	1724
J	0.0 - 205.4°C	1415	L	0.0 - 205.7°C	1815
J	32.0 - 401.7°F	1416	L	32.0 - 402.3°F	1816
J	0 - 450°C	1417	L	0 - 450°C	1817
J	32 - 842°F	1418	L	32 - 842°F	1818
J	0 - 761°C	1419	L	0 - 762°C	1819
J	32 - 1402°F	1420	L	32 - 1404°F	1820
T	-200 - 262°C	1525	B	212 - 3315°F	1934
T	-328 - 504°F	1526	B	100 - 1824°C	1938
T	0.0 - 260.6°C	1541			
T	32.0 - 501.1°F	1542			

For RTD Inputs

Note: Input conditioning jumper JU1 needs to be changed, see Appendix B.

INPUT RANGE	DISPLAYED CODE	INPUT RANGE	DISPLAYED CODE
0 - 600°C	2221	0.0 - 100.9°C	2295
32 - 1112°F	2222	32.0 - 213.6°F	2296
32 - 572°F	2229	-200 - 206°C	2297
-101.0 - 100.0°C	2230	-328 - 403°F	2298
-149.8 - 212.0°F	2231	-101.0 - 300.5°C	7201
0 - 300°C	2251	-149.8 - 572.9°F	7202

For DC Inputs

Note: Input conditioning jumper JU1 needs to be changed, see Appendix B. Also, the Hardware Definition Code for the input type must also be changed, see Appendix C.

INPUT RANGE	DISPLAYED CODE	INPUT RANGE	DISPLAYED CODE
0 - 20mA	3413	0 - 5V	4445
4-20mA	3414	1 - 5V	4434
0 - 50mV	4443	0 - 10V	4446
10 - 50mV	4499	2 - 10V	4450

Appendix E

Specifications

INPUT SPECIFICATIONS

General

Input Sample Rate:	Four per second
Input Resolution:	14 bits approximately
Input Impedance:	Greater than 100M ohm resistive (except for DC mA and V inputs)
Isolation:	Universal input isolated from all outputs except SSR at 240 VAC.

Thermocouple

Types:	R, S, J, T, K, L and B
Calibration:	Complies with BS4937, NBS125 and IEC584.
Sensor Break Protection:	Break detected within 2 seconds. Control outputs set to OFF (0% power); alarms operate as if the process variable has gone over-range.

RTD and DC mV

Type and Connection:	Three-wire Pt100
Calibration:	Complies with BS1904 and DIN43760.
Lead Compensation:	Automatic
Sensor Break Protection:	Break detected within 2 seconds. Control outputs set to OFF (0% power); alarms operate as if the process variable has gone under-range.

DC mA and DC V

Scale Range Maximum:	-1999 to 9999
Scale Range Minimum:	-1999 to 9999
Minimum Span:	1 display LSD
Sensor Break Protection:	Applicable to 4-20mA, 1-5V, and 2-10V ranges only. Break detected within 2 seconds. Control outputs set to OFF (0% power); alarms operate as if the process variable has gone under-range.

OUTPUT SPECIFICATIONS

OUTPUT 1

General

Types Available: Relay (standard), SSR and DC as options.

Relay

Contact Type: SPDT
Rating: 2A resistive at 120/240V AC
Lifetime: > 500,000 operations at rated voltage/current
Isolation: Inherent

SSR Drive/TTL

Drive Capability: SSR>4.2V DC into 1K ohm minimum
Isolation: Not isolated from input or other SSR outputs.

DC

Resolution: Eight bits in 250mS (10 bits in 1 second typical, >10 bits in >1 second typical).
Update Rate: Every control algorithm execution
Ranges: 0-20mA, 4-20mA, 0-10V, and 0-5V*
Load Impedance: 0-20mA: 500 ohm maximum
4-20mA: 500 ohm maximum
0-10V: 500 ohm minimum
0-5V: 500 ohm minimum
Isolation: Isolated from all other inputs and outputs.

*Changes between V and mA ranges also require JU movement.

OUTPUT 2

General

Types Available: Relay, SSR and DC

Relay

Contact Type: SPDT
Rating: 2A resistive at 120/240V AC
Lifetime: > 500,000 operations at rated voltage/current
Isolation: Isolated from all other inputs and outputs

SSR Drive/TTL

Drive Capability: SSR>4.3V DC into 250 ohm minimum
Isolation: Not isolated from input or other SSR outputs

DC

Resolution: Eight bits in 250mS (10 bits in 1 second typical, >10 bits in >1 second typical)
Update Rate: Every control algorithm execution
Ranges: 0-10mA, 4-20mA, 0-10V, and 0-5V*
Load Impedance: 0-20mA: 500 ohm maximum
4-20mA: 500 ohm maximum
0-10V: 500 ohm minimum
0-5V: 500 ohm minimum
Isolation: Isolated from all other inputs and outputs

*Changes between V and mA ranges also require JU movement.

OUTPUT 3

General

Types Available: Relay, SSR and DC linear (retransmit only)

Relay

Contact Type: SPDT
Rating: 2A resistive at 120/240V AC
Lifetime: > 500,000 operations at rated voltage/current
Isolation: Inherent

SSR Drive/TTL

Drive Capability: SSR>4.3V DC into 250 ohm minimum
Isolation: Not isolated from input or other SSR outputs

DC

Resolution: Eight bits in 250mS (10 bits in 1 second typical, >10 bits in >1 second typical).
Update Rate: Every control algorithm execution
Ranges: 0-20mA, 4-20mA, 0-10V, and 0-5V*
Load Impedance: 0-20mA: 500 ohm maximum
4-20mA: 500 ohm maximum
0-10V: 500 ohm minimum
0-5V: 500 ohm minimum

Isolation: Isolated from all other inputs and outputs.

* Changes between V and mA ranges also require JU movement.

CONTROL SPECIFICATIONS

Auto Tune Types: Pre-Tune and Auto-Tune
Proportional Bands: 0 (OFF), 0.5% - 999.9% of input span @ 0.1% increments
Auto Reset: 1s-99min 59s per repeat and OFF
Rate: 0 (OFF) - 99min 59s
Manual Reset: Adjustable in the range 0-100% of output power (single output) or -100% to +100% of output power (dual output)
Deadband/Overlap: -20% to +20% of proportional band 1 + proportional band 2
ON/OFF Hysteresis: 0.1% to 10.0% of input span (control relay only)
Alarm relay hysteresis is fixed at 2°C/F
Auto/Manual Control: User-selectable with "bumpless" transfer into and out of Manual control.
Cycle Times: Selectable for 0.5s to 512s in binary steps
Setpoint Range: Limited by Setpoint Upper and Setpoint Lower limits
Setpoint Ramp: Ramp rate selectable 1-9999 LSDs per hour and infinite. Number displayed is decimal point aligned with selected range.

Alarms

Maximum Number: Two "soft" alarms plus Loop Alarm
Maximum # Outputs: Up to 2 outputs can be used for alarm purposes
Combination Alarms: Logical OR or AND of alrms to an individual hardware output is available.

PERFORMANCE

Reference Conditions

Ambient Temperature: 20°C ± 2°C
Relative Humidity: 60-70%
Supply Voltage: 90-264V AC 50Hz ±1%
Source Resistance: <10 ohm for T/C input
Lead Resistance: <0.1 ohm/lead balanced (Pt100)
Common Mode
Rejection: >120dB at 50/60Hz giving negligible effect at up to 264V 50/60Hz

Series Mode
Rejection: >500% of span (at 50/60Hz) causes negligible effect

DC Linear Inputs

Measurement

Accuracy: $\pm 0.25\%$ of span ± 1 LSD

Thermocouple Inputs

Measurement

Accuracy: $\pm 0.25\%$ of span ± 1 LSD

Note: Reduced performance with Type B T/C
between 100-600 °C (212 - 1112 °F)

Linearization

Accuracy: Better than $\pm 0.2^{\circ}\text{C}$ any point, any 0.1°C range
($\pm 0.05^{\circ}\text{C}$ typical). Better than $\pm 0.5^{\circ}\text{C}$ any point,
any 1°C range.

Cold Junction

Compensation: Better than $\pm 0.7^{\circ}\text{C}$

RTD Inputs

Measurement

Accuracy: $\pm 0.25\%$ of span ± 1 LSD

Linearization

Accuracy: Better than $\pm 0.2^{\circ}\text{C}$ any point, any 0.1°C range
($\pm 0.05^{\circ}\text{C}$ typical). Better than $\pm 0.5^{\circ}\text{C}$ any point,
any 1°C range.

Operating Conditions

Ambient Operating

Temperature: 0 to 55°C

Ambient Storage

Temperature: -20 to 80°C

Relative Humidity: 20% - 95% non-condensing

Supply Voltage: 90 - 264 VAC 50/60 Hz

Source Resistance: 1000 ohm maximum (thermocouple)

Lead Resistance: 50 ohm per lead maximum balanced (Pt 100)

ENVIRONMENTAL

EMI Susceptibility: Designed to meet EN50082 Part 2 1992
EMI Emissions: Designed to meet EN50081 Part 2 1994

PHYSICAL

Dimensions: 1/16 DIN front panel (48mm x 48mm) 4.33 inches deep
Mounting: Plug-in with panel mounting fixing strap.
Panel cut-out 45mm x 45mm.
Terminals: Screw type (combination head)
Power Consumption: Approximately 4 watts
Weight: 8 ounces maximum
Front Panel Sealing: IP65/NEMA4
Display Character Height: Top - .36", bottom - .28"
Agency Approvals: UL and CSA - UL category QUXY8
Process Control Equipment
Certified for Canada
Multiple Listed
File# E67237
Track # 94ML004326

Appendix G
Software Reference Sheet

HDW DEF	
OPTION	

Program	Mode
inPS	
Out1	
ALA1	
ALA2	
USE2	
USE3	
CbS	
CAd	
CJC	

Enable	Mode	
ENAB	ON	OFF
EPro		
EtuN		
ESPC		

(continued on next page)

Tune	Mode
SPrP	
SPrr	
Filt	
iCor	
Po1	
Po2	
Pb1	
Pb2	
ArSt	
rAtE	
SPrd	
rSEt	
HyS1	
HyS2	
HySt	
SPuL	
SPLL	
Pou	
PoL	
o1PL	
Ct1	
Ct2	

Tune	Mode
PHA1	
PLA1	
bAL1	
dAL1	
PHA2	
PLA2	
bAL2	
dAL2	
LAEn	
LAti	
dPoS	
Euu	
EuL	
EPtn	
ESby	
ESPr	
CCon	



THE PARTLOW-WEST COMPANY
2 CAMPION ROAD • NEW HARTFORD, NY 13413 USA
1-800-866-6659 • 315-797-2222 • FAX 315-797-0403