

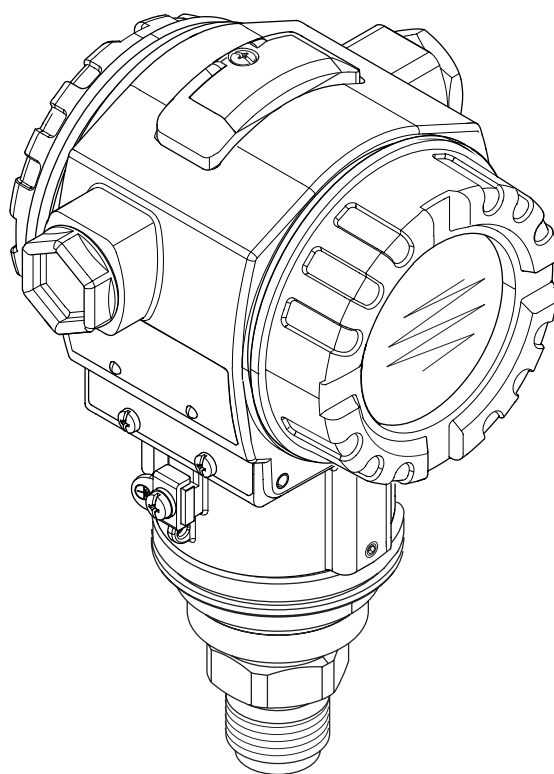

Transmitter PM 50

Pressure - Transmitter



Operating instructions

9499 040 79811

Valid from-Gültig ab-Valable depuis: 8436

Overview documentation

Device	Documentation	Content	Remarks
PM 50 4...20 mA HART	Datasheet 9498-737-51913	Technical data	– The documentation is also available via the Internet. → See: www.pma-online.de → Download
	Operating Instructions 9499-040-79818	<ul style="list-style-type: none"> – Identification – Installation – Wiring – Operation – Commissioning, Description of Quick Setup menus – Maintenance – Trouble-shooting – Appendix: Illustration of menu 	<ul style="list-style-type: none"> – The documentation is supplied with the device. – The documentation is also available via the Internet. → See: www.pma-online.de → Download
	Brief Operating Instructions 9499-047-12441	<ul style="list-style-type: none"> – Wiring – Operation without on-site display – Description of Quick Setup menus 	– The documentation is also available via the Internet. → See: www.pma-online.deonline.de → Download

Table of contents

1	Safety instructions	5
1.1	Designated use	5
1.2	Installation, commissioning and operation	5
1.3	Operational safety	5
1.4	Notes on safety conventions and icons	6
2	Identification	7
2.1	Device designation	7
2.2	Scope of delivery	8
2.3	CE mark, declaration of conformity	8
2.4	Registered trademarks	8
3	Installation	9
3.1	Incoming acceptance and storage	9
3.2	Installation conditions	9
3.3	Installation instructions	9
3.4	Post-installation check	13
4	Wiring	14
4.1	Connecting the device	14
4.2	Connecting the measuring unit	15
4.3	Potential matching	18
4.4	Post-connection check	18
5	Operation	19
5.1	On-site display (optional)	19
5.2	Operating elements	20
5.3	On-site operation – on-site display not connected	23
5.4	On-site operation – on-site display connected	25
5.5	Operation via HART handheld terminal	28
5.6	Commuwin II operating program	28
5.7	Locking/unlocking operation	29
5.8	Factory setting (reset)	30
6	Commissioning	32
6.1	Function check	32
6.2	Selecting language and measuring mode	32
6.3	Position adjustment	32
6.4	Pressure measurement	33
6.5	Level measurement	35
7	Maintenance	38
7.1	Exterior cleaning	38
8	Trouble-shooting	38
8.1	Messages	38
8.2	Response of outputs to errors	44
8.3	Confirming messages	45
8.4	Repair	45

8.5	Repair of Ex-certified devices	45
8.6	Returning the device	46
8.7	Disposal	46
9	Technical data.....	47
10	Appendix.....	47
10.1	Operating menu for on-site display, and HART handheld terminal	47
10.2	Operating matrix HART Commuwin II	53
10.3	Patents	53
	Index	54

1 Safety instructions

1.1 Designated use

The PM 50 is a pressure transmitter for measuring pressure and level.

The manufacturer accepts no liability for damages resulting from incorrect use or use other than that designated.

1.2 Installation, commissioning and operation

The device has been designed to operate safely in accordance with current technical, safety and EU standards. If installed incorrectly or used for applications for which it is not intended, however, it is possible that application-related dangers may arise, e.g. product overflow due to incorrect installation or calibration. For this reason, the instrument must be installed, connected, operated and maintained according to the instructions in this manual: personnel must be authorised and suitably qualified. The manual must have been read and understood, and the instructions followed. Modifications and repairs to the device are permissible only when they are expressly approved in the manual. Pay particular attention to the technical data on the nameplate.

1.3 Operational safety

1.3.1 Hazardous areas (optional)

Devices for use in hazardous areas are fitted with an additional nameplate (→ see Page 7). If the device is to be installed in an explosion hazardous area, then the specifications in the certificate as well as all national and local regulations must be observed. A separate Ex documentation is enclosed with the device and is an integral part of this documentation. The installation regulations, connection values and Safety Instructions listed in this document must be observed. The documentation number of the related Safety Instructions (ATEX) is also indicated on the additional nameplate.



- Ensure that all personnel are suitably qualified.



1.3.2 Functional Safety SIL 2 (optional)





If using devices for SIL 2 applications, the separate manual on functional safety must be observed thoroughly.

1.4 Notes on safety conventions and icons

In order to highlight safety-relevant or alternative operating procedures in the manual, the following conventions have been used, each indicated by a corresponding icon in the margin.

Symbol	Meaning
	Warning! A warning highlights actions or procedures which, if not performed correctly, will lead to personal injury, a safety hazard or destruction of the instrument.
	Caution! Caution highlights actions or procedures which, if not performed correctly, may lead to personal injury or incorrect functioning of the instrument.
	Note! A note highlights actions or procedures which, if not performed correctly, may indirectly affect operation or may lead to an instrument response which is not planned.

	Device certified for use in explosion hazardous area If the device has this symbol embossed on its nameplate, it can be installed in an explosion hazardous area or a non-explosion hazardous area, according to the approval.
	Explosion hazardous area Symbol used in drawings to indicate explosion hazardous areas. – Devices used in hazardous areas must possess an appropriate type of protection.
	Safe area (non-explosion hazardous area) Symbol used in drawings to indicate, if necessary, non-explosion hazardous areas. – Devices used in hazardous areas must possess an appropriate type of protection. Lines used in hazardous areas must meet the necessary safety-related characteristic quantities.

	Direct voltage A terminal to which or from which a direct current or voltage may be applied or supplied.
	Alternating voltage A terminal to which or from which an alternating (sine-wave) current or voltage may be applied or supplied.
	Grounded terminal A grounded terminal, which as far as the operator is concerned, is already grounded by means of an earth grounding system.
	Protective grounding (earth) terminal A terminal which must be connected to earth ground prior to making any other connection to the equipment.
	Equipotential connection (earth bonding) A connection made to the plant grounding system which may be of type e.g. neutral star or equipotential line according to national or company practice.

2 Identification

2.1 Device designation

2.1.1 Nameplate

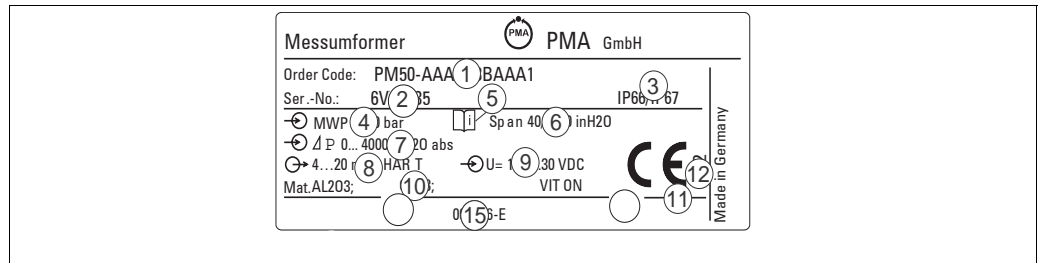

Fig. 1: Nameplate for PM 50

- 1 Order code
See the specifications on the order confirmation for the meanings of the individual letters and digits.
- 2 Serial number
- 3 Degree of protection
- 4 MWP (Maximum working pressure)
- 5 Symbol: Note: pay particular attention to the data in the "Technical Information"!
- 6 Minimum/maximum span
- 7 Nominal measuring range
- 8 Electronic version (output signal)
- 9 Supply voltage
- 10 Wetted materials
- 11 ID number of notified body with regard to Pressure Equipment Directive (optional)
- 12 ID number of notified body with regard to ATEX (optional)
- 15 Layout identification of the nameplate

Devices for use in hazardous areas are fitted with an additional nameplate.

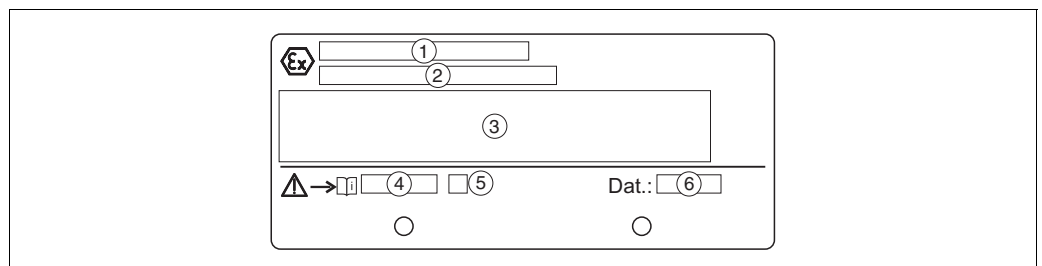

Fig. 2: Additional nameplate for devices for hazardous areas

- 1 EC type examination certificate number
- 2 Type of protection e.g. II 1/2 G EEx ia IIC T4/T6
- 3 Electrical data
- 4 Safety Instructions number e.g. XA XXX
- 5 Safety Instructions index e.g. A
- 6 Device manufacture data (month and year)

**Note!**

- The MWP (maximum working pressure) is specified on the nameplate. This value refers to a reference temperature of 20°C (68°F) or 100°F for ANSI flanges.
- The pressure values permitted at higher temperatures can be found in the following standards:
 - EN 1092-1: 2001 Tab. 18 ¹
 - ASME B 16.5a – 1998 Tab. 2-2.2 F316
 - ASME B 16.5a – 1998 Tab. 2.3.8 N10276
 - JIS B 2220
- The test pressure corresponds to the over pressure limit (OPL) of the device = MWP x 1.5.
- The Pressure Equipment Directive (EC Directive 97/23/EC) uses the abbreviation "PS". The abbreviation "PS" corresponds to the MWP (maximum working pressure) of the measuring device.

1) With regard to its stability-temperature property, the material 1.4435 is identical to 1.4404 which is grouped under 13EO in EN 1092-1 Tab. 18. The chemical composition of the two materials can be identical.

2.2 Scope of delivery

The scope of delivery comprises:

- PM 50 pressure transmitter
- Optional accessories

Documentation supplied:

- Operating Instructions 9499-040-79811 (this document)
- Brief Operating Instructions 9499-047-12441
- Final inspection report
- Optional: factory calibration form
- Devices which are suitable for use in hazardous areas:
additional documentation such as Safety Instructions (ATEX)

2.3 CE mark, declaration of conformity

The device is designed to meet state-of-the-art safety requirements, has been tested and left the factory in a condition in which it is safe to operate. The device complies with the applicable standards and regulations as listed in the EC declaration of conformity and thus complies with the statutory requirements of the EC Directives. PMA GmbH confirms the successful testing of the device by affixing to it the CE mark.

2.4 Registered trademarks

KALREZ, VITON, TEFLON

Registered trademarks of E.I. Du Pont de Nemours & Co., Wilmington, USA

TRI-CLAMP

Registered trademark of Ladish & Co., Inc., Kenosha, USA

HART

Registered trademark of the HART Communication Foundation, Austin, USA.

3 Installation

3.1 Incoming acceptance and storage

3.1.1 Incoming acceptance

- Check the packaging and the contents for damage.
- Check the shipment, make sure nothing is missing and that the scope of supply matches your order.

3.1.2 Storage

The device must be stored in a dry, clean area and protected against damage from impact (EN 837-2).

Storage temperature range:

- $-40\dots+100^{\circ}\text{C}$ ($-40\dots+212^{\circ}\text{F}$)
- On-site display: $-40\dots+85^{\circ}\text{C}$ ($-40\dots+185^{\circ}\text{F}$)

3.2 Installation conditions

3.2.1 Dimensions

→ For dimensions, please refer to the Datasheet 9498-737-51913, "Mechanical construction" section. See page 2, "Overview documentation".

3.3 Installation instructions



Note!

- Due to the orientation of the PM 50, there may be a shift in the measured value, i.e. when the container is empty, the measured value does not display zero. This zero point shift can be corrected. → See page 32, section 6.3 "Position adjustment".
- To ensure optimal readability of the on-site display, it is possible to rotate the housing up to 380° . → See page 13, section 3.3.5 "Rotating the housing".
- PMA offers a mounting bracket for installing on pipes or walls. → See page 13, section 3.3.4 "Wall and pipe mounting".

3.3.1 Installation instructions for devices without diaphragm seals



Note!

- PM 50 without diaphragm seal are mounted as per the norms for a manometer (DIN EN 839-2). We recommend the use of shut-off devices and siphons. The orientation depends on the measuring application.
- Do not clean or touch diaphragm seals with hard or pointed objects.

Pressure measurement in gases

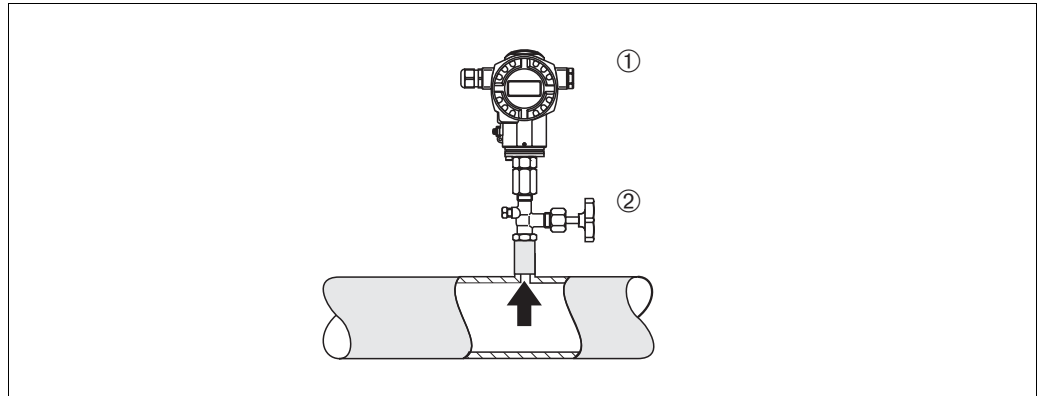

Fig. 3: Measuring arrangement for pressure measurement in gases

- 1 PM 50
- 2 Shut-off device

- Mount PM 50 with shut-off device above the tapping point so that the condensate can flow into the process.

Pressure measurement in vapours

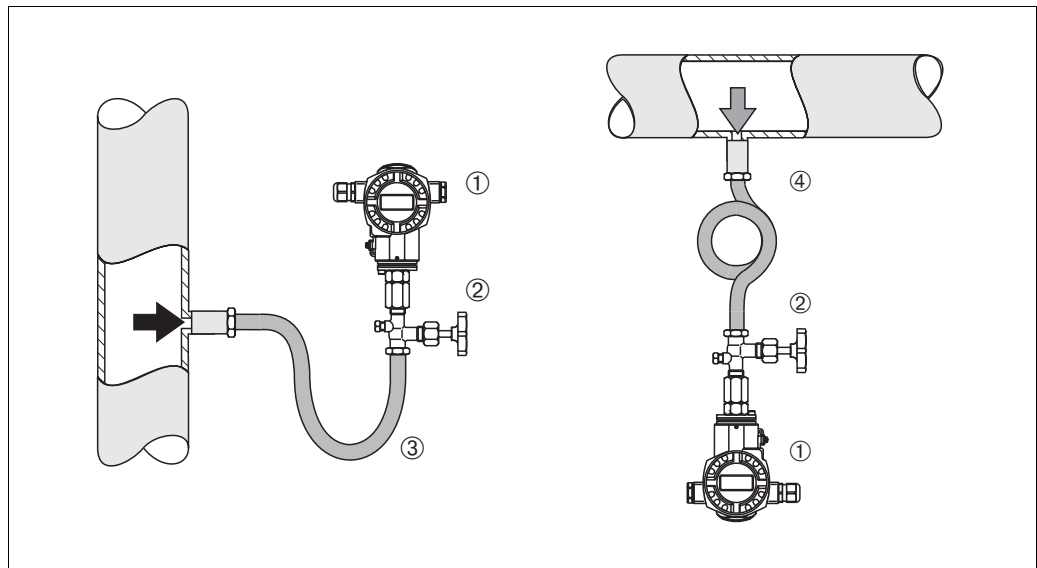

Fig. 4: Measuring arrangement for pressure measurement in vapours

- 1 PM 50
- 2 Shut-off device
- 3 U-shaped siphon
- 4 Circular siphon

- Mount PM 50 with siphon below the tapping point.
The siphon reduces the temperature to almost ambient temperature.
- Fill the siphon with fill fluid before commissioning.

Pressure measurement in liquids

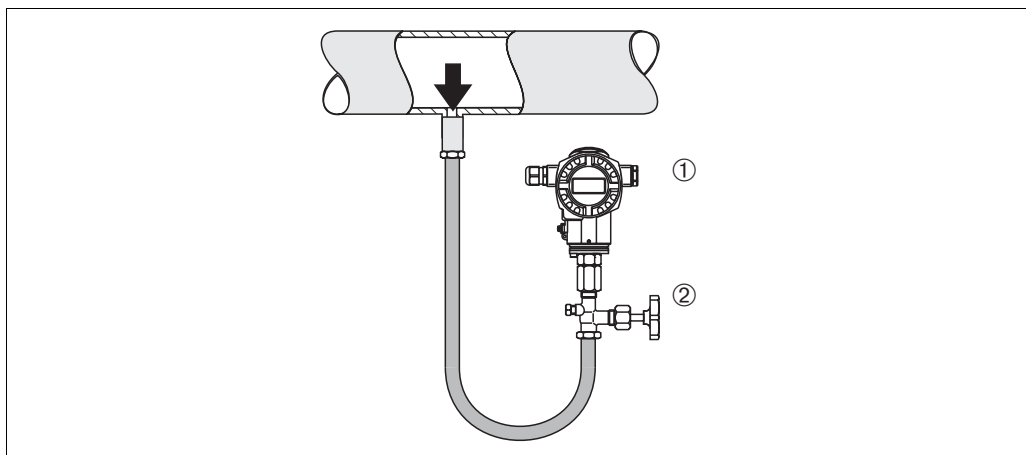

Fig. 5: Measuring arrangement for pressure measurement in liquids

- 1 PM 50
- 2 Shut-off device

- Mount PM 50 with shut-off device below or at the same level as the tapping point.

Level measurement

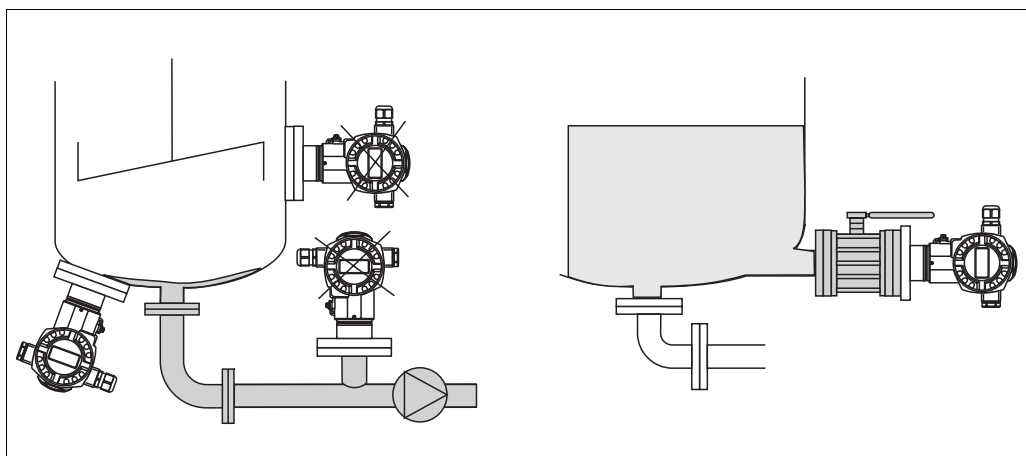
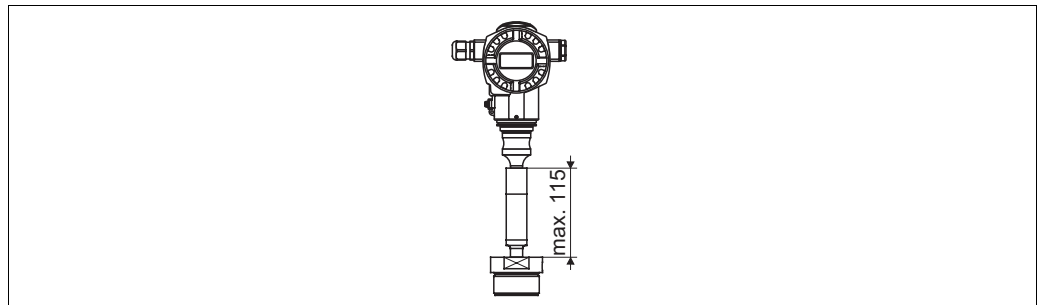

Fig. 6: Measuring arrangement for level

- Mount PM 50 below the lowest measuring point.
- Do not mount the device at the following positions:
In the fill flow, in the tank outlet or at a point in the container which could be affected by pressure pulses from the agitator.
- The calibration and functional test can be carried out more easily if you mount the device after a shut-off device.

3.3.2 Installation instructions for devices with diaphragm seals – PM5x

Mounting with temperature separator



PMA recommends the use of temperature separators in the event of constant extreme fluid temperatures which lead to the maximum permissible electronics temperature of +85°C (+185°F) being exceeded.

The additional installation height also brings about a zero point shift of approx. 21 mbar due to the hydrostatic columns in the temperature separator. You can correct this zero point shift. → See also page 32, section 6.3 "Position adjustment".

3.3.3 Heat insulation – PM50 high temperature version

The PM50 (high temperature version) must only be insulated up to a certain height. The maximum permitted insulation height is labelled on the devices and applies to an insulation material with a heat conductivity $\leq 0.04 \text{ W}/(\text{m} \times \text{K})$ and to the maximum permitted ambient and process temperature (→ see table below). The data were determined under the most critical application "quiescent air".

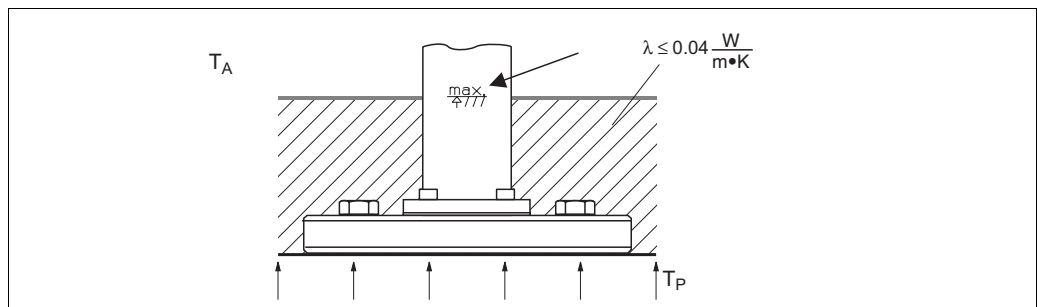
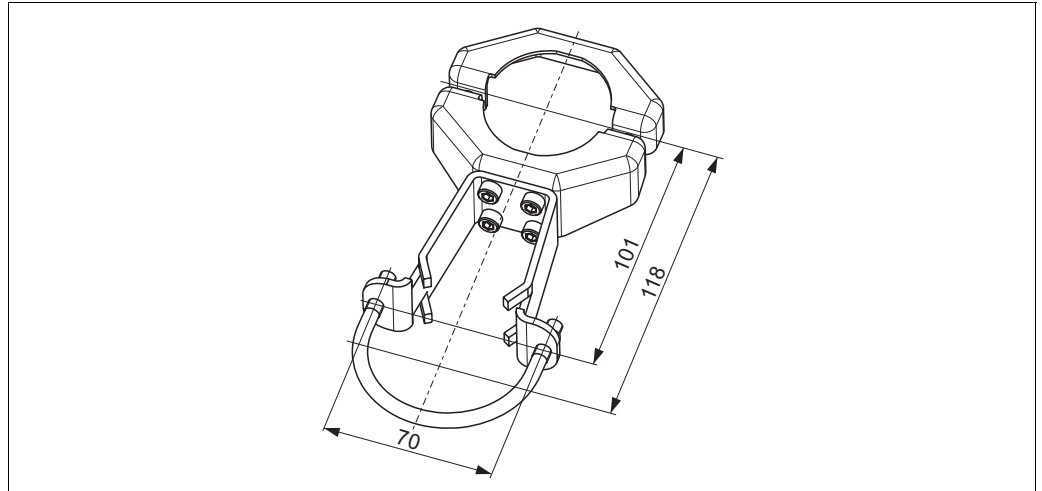

Fig. 7: Maximum insulation height, here with flange

	PM50 high temperature version
Ambient temperature (T_A)	$\leq 70^\circ\text{C}$ (158°F)
Process temperature (T_P)	$\leq 150^\circ\text{C}$ (302°F)

3.3.4 Wall and pipe-mounting (optional)

PMA offers a mounting bracket for installing on pipes or walls.



Please note the following when mounting:

- The cable entry should always point downwards so that moisture on the connecting cable can drain off and not penetrate the housing.
- In the case of pipe mounting, the nuts on the bracket must be tightened uniformly with a torque of at least 5 Nm.

3.3.5 Rotating the housing

The housing can be rotated up to 380° by loosening the Allen screw.

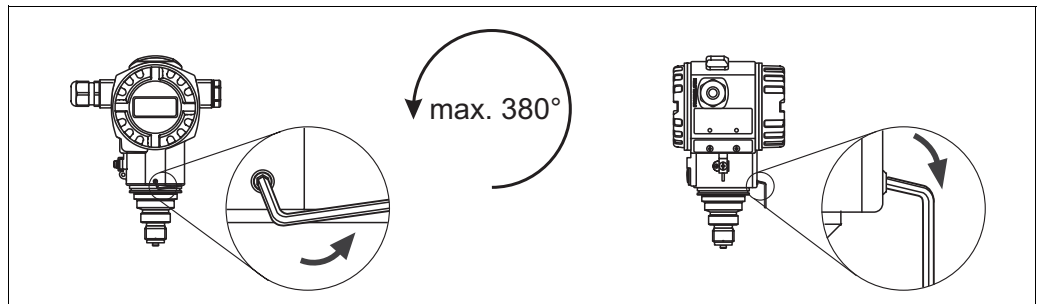

Fig. 8: Aligning the housing

- Housing: Loosen setscrew with a 2 mm Allen key.
- Rotate housing (max. up to 380°).
- Retighten setscrew.

3.4 Post-installation check

After installing the device, carry out the following checks:

- Are all screws firmly tightened?
- Are the housing covers screwed down tight?

4 Wiring

4.1 Connecting the device



Note!

- When using the measuring device in hazardous areas, installation must comply with the corresponding national standards and regulations and the Safety Instructions (ATEX).
 - Devices with integrated overvoltage protection must be earthed.
 - Protective circuits against reverse polarity, HF influences and overvoltage peaks are installed.
- The supply voltage must match the supply voltage on the nameplate. (→ See also page 7, section 2.1.1 Nameplate.)
 - Switch off the supply voltage before connecting the device.
 - Remove housing cover of the terminal compartment.
 - Guide cable through the gland. Preferably use twisted, screened two-wire cable.
 - Connect device in accordance with the following diagram.
 - Screw down housing cover.
 - Switch on supply voltage.

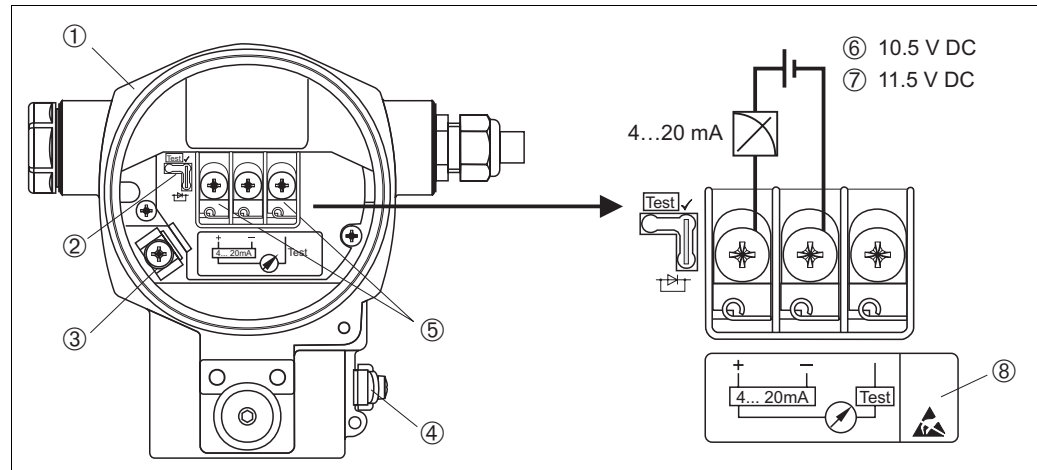

Fig. 9: Electrical connection 4...20 mA HART
→ Observe also section 4.2.1 "Supply voltage", page 15.

- 1 Housing
- 2 Jumper for 4...20 mA test signal.
→ See also page 15, section 4.2.1, "Taking 4...20 mA test signal" part.
- 3 Internal earth terminal
- 4 External earth terminal
- 5 4...20 mA test signal between plus and test terminal
- 6 minimum supply voltage = 10.5 V DC, jumper is inserted in accordance with the illustration.
- 7 minimum supply voltage = 11.5 V DC, jumper is inserted in "Test" position.
- 8 Devices with integrated overvoltage protection are labelled OVP (overvoltage protection) here.

4.1.1 Connecting devices with Harting plug Han7D

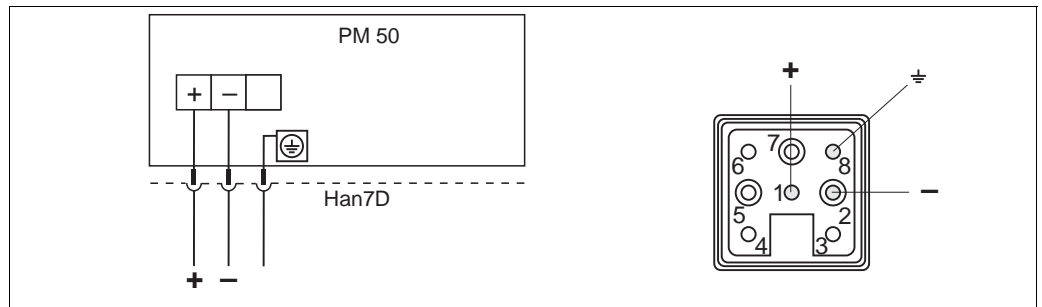

Fig. 10: Left: electrical connection for devices with Harting plug Han7D
Right: view of the plug at the device

4.2 Connecting the measuring unit

4.2.1 Supply voltage



Note!

- All explosion protection data are given in separate documentation which is available upon request. The Ex documentation is supplied as standard with all devices approved for use in explosion hazardous areas.
- When using the measuring device in hazardous areas, installation must comply with the corresponding national standards and regulations and the Safety Instructions (ATEX).

Electronic version	Jumper for 4...20 mA test signal in "Test" position (Delivery status)	Jumper for 4...20 mA test signal in "Non-Test" position
4...20 mA HART, for non-hazardous areas	11.5...45 V DC	10.5...45 V DC

Taking 4...20 mA test signal

A 4...20 mA signal may be measured via the positive and test terminal without interrupting the measurement. The minimum supply voltage of the device can be reduced by simply changing the position of the jumper. As a result, operation is also possible with lower voltage sources. To keep the measured error below 0.1%, the current measuring device should display an internal resistance of < 0.7 Ω. Observe the position of the jumper in accordance with the following table.

Jumper position for test signal	Description
	<ul style="list-style-type: none"> - Taking 4...20 mA test signal via plus and test terminal: possible. (Thus, the output current can be measured without interruption via the diode.) - Delivery status - minimum supply voltage: 11.5 V DC
	<ul style="list-style-type: none"> - Taking 4...20 mA test signal via plus and test terminal: not possible. - minimum supply voltage: 10.5 V DC

4.2.2 Cable specification

- PMA recommends using twisted, screened two-wire cables.
- Terminals for wire cross-sections 0.5...2.5 mm²
- Cable external diameter: 5...9 mm

4.2.3 Load

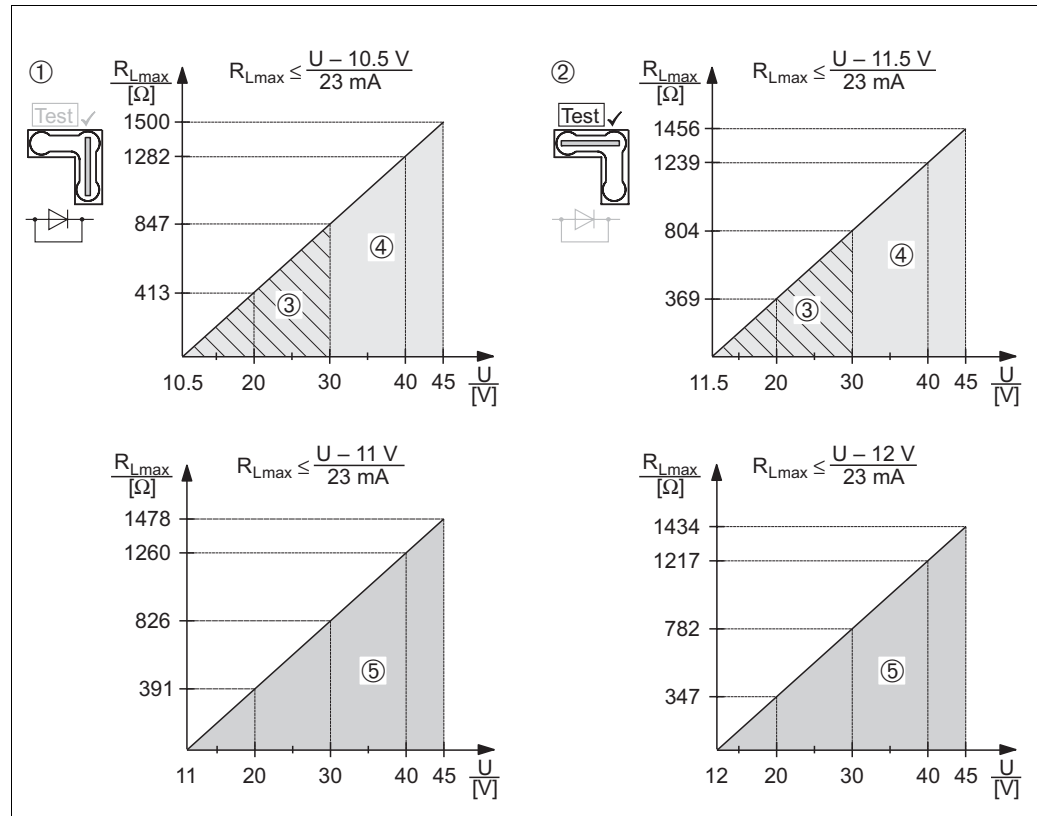

Fig. 11: Load diagram, observe the position of the jumper and the explosion protection. (→ See also page 15, "Taking 4...20 mA test signal" part.)

- 1 Jumper for the 4...20 mA test signal inserted in "Non-Test" position
 - 2 Jumper for the 4...20 mA test signal inserted in "Test" position
 - 3 Supply voltage 10,5 (11,5)...30 V DC for EEx ia,
 - 4 Supply voltage 10,5 (11,5)...45 V DC for devices for non-hazardous areas,
- R_{Lmax} Maximum load resistance
 U Supply voltage



Note!

When operating via a handheld terminal or via PC with an operating program, a minimum communication resistance of 250 Ω must exist within the loop.

4.2.4 Screening/potential matching

- You achieve optimum screening against disturbances if the screening is connected on both sides (in the cabinet and on the device). If you have to reckon with potential equalisation currents in the plant, only earth screening on one side, preferably at the transmitter.
- When using in hazardous areas, you must observe the applicable regulations. Separate Ex documentation with additional technical data and instructions is included with all Ex systems as standard.
- Ex applications: set up potential matching inside and outside the hazardous area. Connect all devices to the local potential matching.

4.2.5 Connecting HART handheld terminal

With a HART handheld terminal you can set and check the transmitter and avail of additional functions all along the 4...20 mA line.

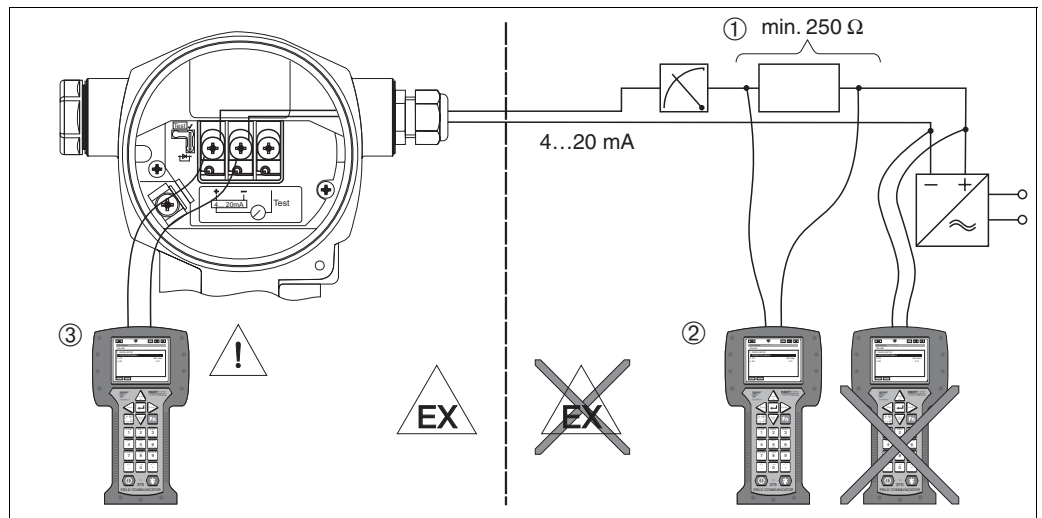

Fig. 12: Connecting a HART handheld terminal, e.g. Field Communicator DXR375

- 1 Necessary communication resistor $\geq 250 \Omega$
- 2 HART handheld terminal
- 3 HART handheld terminal, directly connected to the device even in the Ex i-area



Warning!

- In the case of Ex d type of protection, do not connect the handheld terminal in the hazardous area.
- Do not replace the battery of the handheld terminal in the hazardous area.

4.2.6 Connecting Commubox FXA191 for operation via Commuwin II

The Commubox FXA 191 connects Smart Transmitters with HART protocol to the serial interface (RS 232) of a computer. This makes it possible to remotely operate the transmitters with the aid of the operating program Commuwin II. The Commubox is also suitable for use in intrinsically safe circuits.

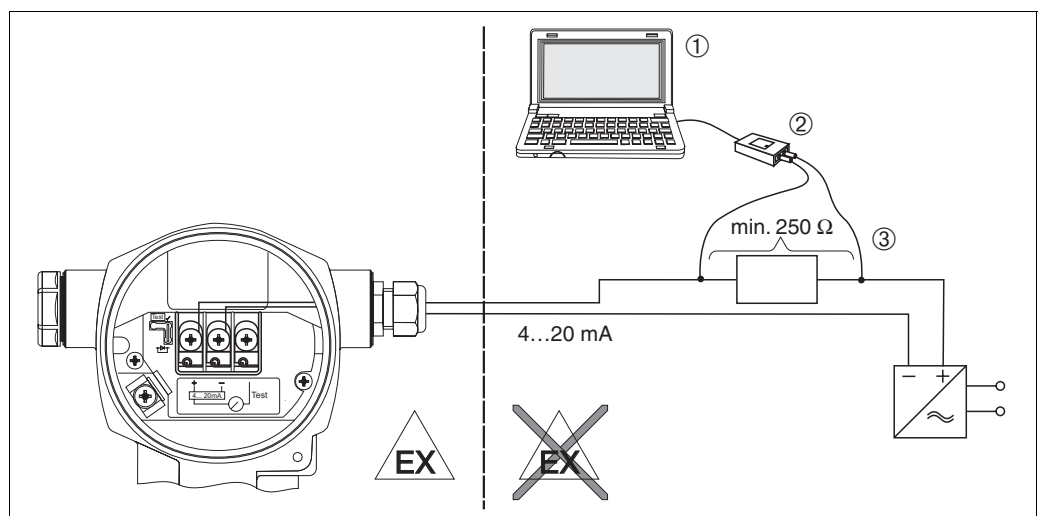

Fig. 13: Connecting PC with operating programs Commuwin II via Commubox FXA 191

- 1 Computer with operating program Commuwin II
- 2 Commubox FXA191
- 3 Necessary communication resistor $\geq 250 \Omega$

4.3 Potential matching

Potential matching does not have to be set up.

4.4 Post-connection check

Perform the following checks after completing electrical installation of the device:

- Does the supply voltage match the specifications on the nameplate?
- Is the device connected as per section 4.1?
- Are all screws firmly tightened?
- Are the housing covers screwed down tight?

As soon as voltage is applied to the device, the green LED on the electronic insert lights up for a few seconds or the connected on-site display lights up.

5 Operation

Feature 20 "Output; operation" in the order code provides you with information on the operating options available to you.

Versions in the order code		Operation
A	4...20 mA HART; external operation, LCD	Via on-site display and 1 key on the exterior of the device
C	4...20 mA; internal operation	Without on-site display, 1 key on the inside of the device

5.1 On-site display (optional)

A 4-line liquid crystal display (LCD) is used for display and operation. The on-site display shows measured values, dialog texts, fault messages and notice messages.

Functions:

- 8-digit measured value display including sign and decimal point, bargraph for current display
- simple and complete menu guidance thanks to separation of the parameters into several levels and groups
- each parameter is given a 3-digit ID number for easy navigation
- option for configuring the display according to individual requirements and desires, such as language, alternating display, contrast setting, display of other measured values such as sensor temperature
- comprehensive diagnostic functions (fault and warning message, peak-hold indicators, etc.)
- rapid and safe commissioning with the Quick Setup menus

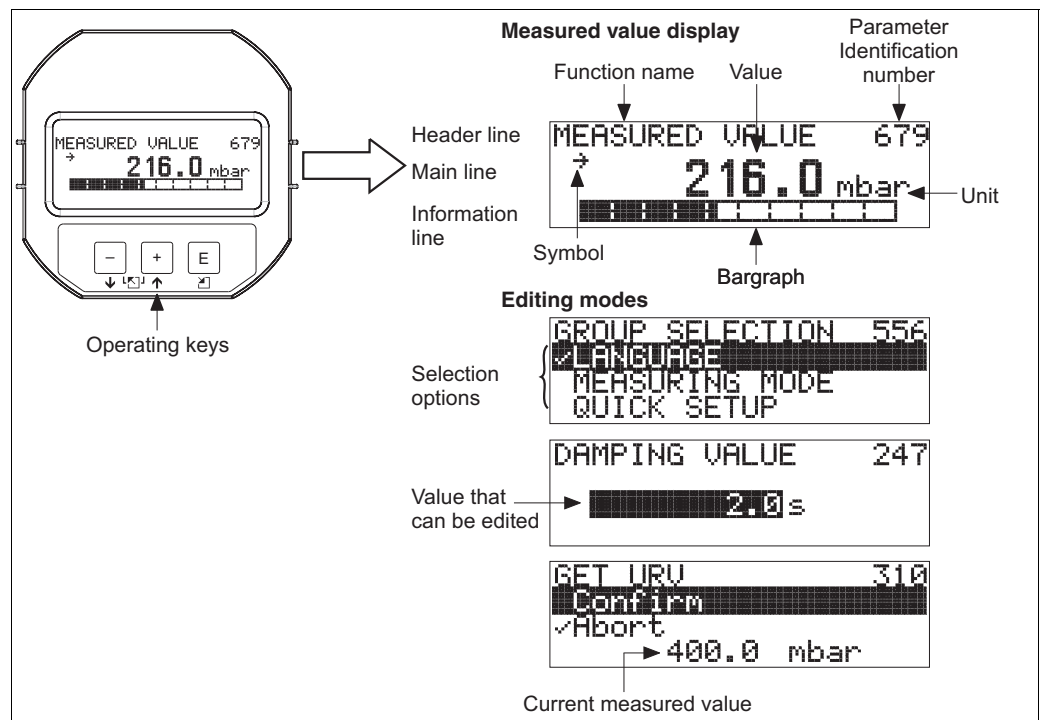

The following table illustrates the symbols that can appear on the on-site display. Four symbols can occur at one time.

Symbol	Meaning
	Alarm symbol – Symbol flashing: warning, device continues measuring. – Symbol permanently lit: error, device does not continue measuring. Note: The alarm symbol may overlie the tendency symbol.
	Lock symbol The operation of the device is locked. Unlock device, → see section 5.10.
	Communication symbol Data transfer via communication Note: The alarm symbol may overlie the communication symbol.
	Square root symbol Active measuring mode "Flow measurement" The root flow signal is used for the current output.
	Tendency symbol (increasing) The measured value is increasing.
	Tendency symbol (decreasing) The measured value is decreasing.
	Tendency symbol (constant) The measured value has remained constant over the past few minutes.

5.2 Operating elements

5.2.1 Position of operating elements

The operating keys are located either under the protective cap on the exterior of the device or inside on the electronic insert. Operating keys are also located on the optional on-site display.

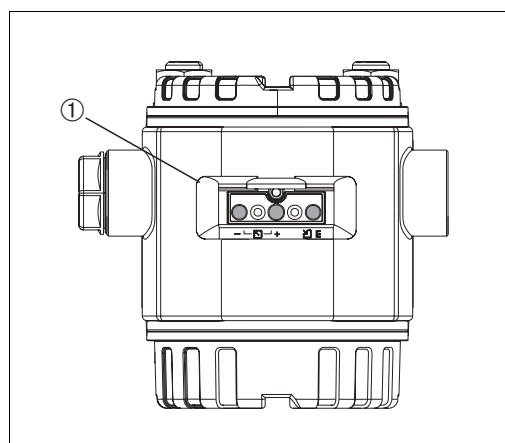

Fig. 14: Operating keys, external

- 1 Operating keys on the exterior of the device under the protective flap

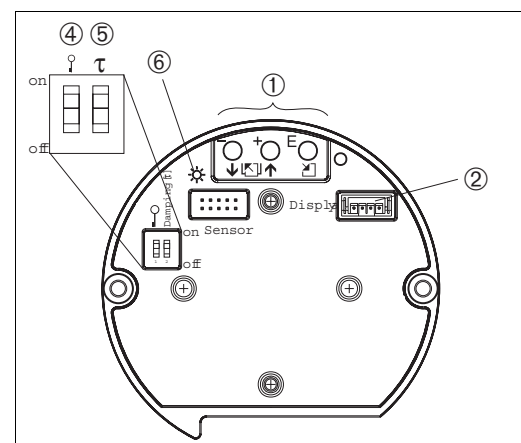









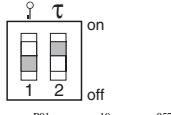

Fig. 15: Operating keys, internal

- 1 Operating keys
- 2 Slot for optional display
- 4 DIP-switch for locking/unlocking measured-value-relevant parameters
- 6 DIP-switch for damping on/off
- 7 Green LED to indicate value being accepted



5.2.2 Function of the operating elements – on-site display not connected

Operating key(s)	Meaning
	<p> Note!</p> <ul style="list-style-type: none"> • The device is configured for the pressure measuring mode as standard. You can switch measuring modes by means of the MEASURING MODE parameter. → See page 32, section 6.2 "Selecting language and measuring mode". • Press the key for at least 3 seconds to accept the pressure value applied. <p>MEASURING MODE "Pressure":</p> <ul style="list-style-type: none"> • The pressure applied is assigned to the lower current value (SET LRV – pressure¹). <p> Note!</p> <ul style="list-style-type: none"> • MEASURING MODE "Level": The factory settings for the LEVEL MODE, CALIBRATION MODE, LIN. MEASURAND, EMPTY CALIB. and FULL CALIB. parameters are as follows: <ul style="list-style-type: none"> – LEVEL MODE = Linear – CALIBRATION MODE = wet – LIN. MEASURAND = % – EMPTY CALIB. = 0 % – FULL CALIB. = 100 %. These parameters can only be modified by means of the on-site display. <p>MEASURING MODE "Level", CALIBRATION MODE "wet":</p> <ul style="list-style-type: none"> • LEVEL MODE "Linear": <ul style="list-style-type: none"> – The pressure applied is saved as the lower pressure value (EMPTY PRESSURE¹) and assigned to the lower level value (EMPTY CALIB.¹). The lower level and current values (SET LRV - level¹) remain unchanged. These values can only be modified by means of the on-site display. → See also page 36, section 6.5.2 "Quick Setup menu for Level measuring mode" and Operating Instructions 9499-040-79811, parameter descriptions LEVEL MODE, CALIBRATION MODE, EMPTY CALIB., EMPTY PRESSURE and SET LRV – Level. • LEVEL MODE "Pressure Linearized" or "Height Linearized": <ul style="list-style-type: none"> – The key does not have any function. <p>MEASURING MODE "Level", CALIBRATION MODE "dry":</p> <ul style="list-style-type: none"> • The key does not have any function.

Operating key(s)	Meaning
	<p> Note!</p> <ul style="list-style-type: none"> The device is configured for the pressure measuring mode as standard. You can switch measuring modes by means of the MEASURING MODE parameter. → See page 32, section 6.2 "Selecting language and measuring mode". Press the key for at least 3 seconds to accept the pressure value applied. <p>MEASURING MODE "Pressure":</p> <ul style="list-style-type: none"> The pressure applied is assigned to the upper current value (SET URV – pressure¹). <p> Note!</p> <p>MEASURING MODE "Level":</p> <p>The factory settings for the LEVEL MODE, CALIBRATION MODE, LIN. MEASURAND, EMPTY CALIB. and FULL CALIB. parameters are as follows:</p> <ul style="list-style-type: none"> LEVEL MODE = Linear CALIBRATION MODE = wet LIN. MEASURAND = % EMPTY CALIB. = 0 % FULL CALIB. = 100 %. <p>These parameters can only be modified by means of the on-site display.</p> <p>MEASURING MODE "Level", CALIBRATION MODE "wet":</p> <ul style="list-style-type: none"> LEVEL MODE "Linear": <ul style="list-style-type: none"> The pressure applied is saved as the upper pressure value (FULL PRESSURE¹) and assigned to the upper level value (FULL CALIB.¹). The upper level and current values (SET URV - level¹) remain unchanged. These values can only be modified by means of the on-site display. <ul style="list-style-type: none"> → See also page 36, section 6.5.2 "Quick Setup menu for Level measuring mode" and Operating Instructions 9499-040-79811, parameter descriptions LEVEL MODE, CALIBRATION MODE, FULL CALIB., FULL PRESSURE, and SET URV – Level. LEVEL MODE "Pressure Linearized" or "Height Linearized": <ul style="list-style-type: none"> The key does not have any function. <p>MEASURING MODE "Level", CALIBRATION MODE "dry":</p> <ul style="list-style-type: none"> The key does not have any function.
	<p>Position adjustment (Press key for at least 3 s.)</p>
 and  and 	<p>Reset all parameters. The reset via operating keys corresponds to the software reset code 7864. (Press key for at least 6s.)</p>
	<ul style="list-style-type: none"> DIP-switch 1: for locking/unlocking measured-value-relevant parameters Factory setting: off (unlocked) DIP-switch 2: damping on/off, Factory setting: on (damping on)

1) Parameter name used for the on-site display.

5.2.3 Function of the operating elements – on-site display connected

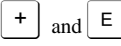
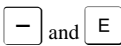
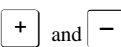
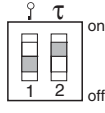
Operating key(s)	Meaning
	<ul style="list-style-type: none"> – Navigate upwards in the picklist – Edit the numerical values and characters within a function
	<ul style="list-style-type: none"> – Navigate downwards in the picklist – Edit the numerical values and characters within a function
	<ul style="list-style-type: none"> – Confirm entry – Jump to the next item
	Contrast setting of on-site display: darker
	Contrast setting of on-site display: brighter
	<p>ESC functions:</p> <ul style="list-style-type: none"> – Exit edit mode without saving the changed value. – You are in a menu within a function group. The first time you press the keys simultaneously, you go back a parameter within the function group. Each time you press the keys simultaneously after that, you go up a level in the menu. – You are in a menu at a selection level. Each time you press the keys simultaneously, you go up a level in the menu. <p>Note: The terms function group, level and selection level are explained in section 5.4.1, page 25.</p>
	<ul style="list-style-type: none"> – DIP-switch 1: for locking/unlocking measured-value-relevant parameters Factory setting: off (unlocked) – DIP-switch 2: damping on/off, Factory setting: on (damping on)

5.3 On-site operation – on-site display not connected

5.3.1 Pressure measuring mode

If no on-site display is connected, the following functions are possible by means of the three keys on the electronic insert or on the exterior of the device:

- Position adjustment (zero point correction)
- Setting lower range value and upper range value
- Device reset, → see also page 21, section 5.2.2 "Function of the operating elements", Table.



Note!

- The operation must be unlocked. → See page 29, section 5.10 "Locking /unlocking operation".
- The device is configured for the Pressure measuring mode as standard. You can switch measuring modes by means of the MEASURING MODE parameter. → See page 32, section 6.2 "Selecting language and measuring mode".
- The pressure applied must be within the nominal pressure limits of the sensor. See information on the nameplate.

Carry out position adjustment.	Setting lower range value.	Setting upper range value.
Pressure is present at device.	Desired pressure for lower range value is present at device.	Desired pressure for upper range value is present at device.
↓	↓	↓

Carry out position adjustment.		Setting lower range value.		Setting upper range value.	
Press "E"-key for 3 s.		Press "-"-key for 3 s.		Press "+"-key for 3 s.	
↓		↓		↓	
Does the LED on the electronic insert light up briefly?		Does the LED on the electronic insert light up briefly?		Does the LED on the electronic insert light up briefly?	
Yes	No	Yes	No	Yes	No
↓	↓	↓	↓	↓	↓
Applied pressure for position adjustment has been accepted.	Applied pressure for position adjustment has not been accepted. Observe the input limits.	Applied pressure for lower range value has been accepted.	Applied pressure for lower range value has not been accepted. Observe the input limits.	Applied pressure for upper range value has been accepted.	Applied pressure for upper range value has not been accepted. Observe the input limits.

5.3.2 Level measuring mode



Note!

If no on-site display is connected, the following functions are possible by means of the three keys on the electronic insert or on the exterior of the device:

- Position adjustment (zero point correction)
- Set the lower and upper pressure value and assign to the lower and upper level value
- Device reset, → see also page 21, section 5.2.2 "Function of the operating elements", Table.

- The operation must be unlocked. → See page 29, section 5.10 "Locking /unlocking operation".
- The device is configured for the Pressure measuring mode as standard. You can switch measuring modes by means of the MEASURING MODE parameter. → See page 32, section 6.2 "Selecting language and measuring mode".
- The \square and \oplus keys do not have any function if the LEVEL MODE "Pressure linearized" or "Height linearized" or the CALIBRATION MODE "dry" was selected.
- The factory settings for the LEVEL MODE, CALIBRATION MODE, LIN. MEASURAND, EMPTY CALIB. and FULL CALIB. parameters are as follows:
 - LEVEL MODE = Linear
 - CALIBRATION MODE = wet
 - LIN. MEASURAND = %
 - EMPTY CALIB. = 0 %
 - FULL CALIB. = 100 %.
 These parameters can only be modified by means of the on-site display.
- The pressure applied must be within the nominal pressure limits of the sensor. See information on the nameplate.
- → See also page 36, section 6.5.2 "Quick Setup menu for Level measuring mode" and Operating Instructions 9499-040-79811, parameter descriptions LEVEL MODE, CALIBRATION MODE, EMPTY CALIB., FULL CALIB., EMPTY PRESSURE, FULL PRESSURE, SET LRV – Level and SET URV – Level.

Carry out position adjustment.	Setting lower pressure value.	Setting upper pressure value.
Pressure is present at device.	Desired pressure for lower pressure value (EMPTY PRESSURE ¹) is present at device.	Desired pressure for upper pressure value (FULL PRESSURE ¹) is present at device.
↓	↓	↓
Press "E"-key for 3 s.	Press "-"-key for 3 s.	Press "+"-key for 3 s.
↓	↓	↓
Does the LED on the electronic insert light up briefly?	Does the LED on the electronic insert light up briefly?	Does the LED on the electronic insert light up briefly?

Carry out position adjustment.		Setting lower pressure value.		Setting upper pressure value.	
Yes	No	Yes	No	Yes	No
↓	↓	↓	↓	↓	↓
Applied pressure for position adjustment has been accepted.	Applied pressure for position adjustment has not been accepted. Observe the input limits.	The pressure present was saved as the lower pressure value (EMPTY PRESSURE ¹⁾) and assigned to the lower level value (EMPTY CALIB. ¹⁾).	The pressure present was not saved as the lower pressure value. Observe the input limits.	The pressure present was saved as the upper pressure value (FULL PRESSURE ¹⁾) and assigned to the upper level value (FULL CALIB. ¹⁾).	The pressure present was not saved as the upper pressure value. Observe the input limits.

1) Parameter name used for the on-site display.

5.4 On-site operation – on-site display connected

If the on-site display is connected, the three operating keys are used to navigate through the operating menu, → see page 23, section 5.2.3 "Function of the operating elements".

5.4.1 General structure of the operating menu

The menu is split into four levels. The three upper levels are used to navigate while you use the bottom level to enter numerical values, select options and save settings. The entire menu is illustrated in section 10.1 "Menu for on-site display and HART handheld terminal".

The structure of the OPERATING MENU depends on the measuring mode selected, e.g. if the "Pressure" measuring mode is selected, only the functions necessary for this mode are displayed.

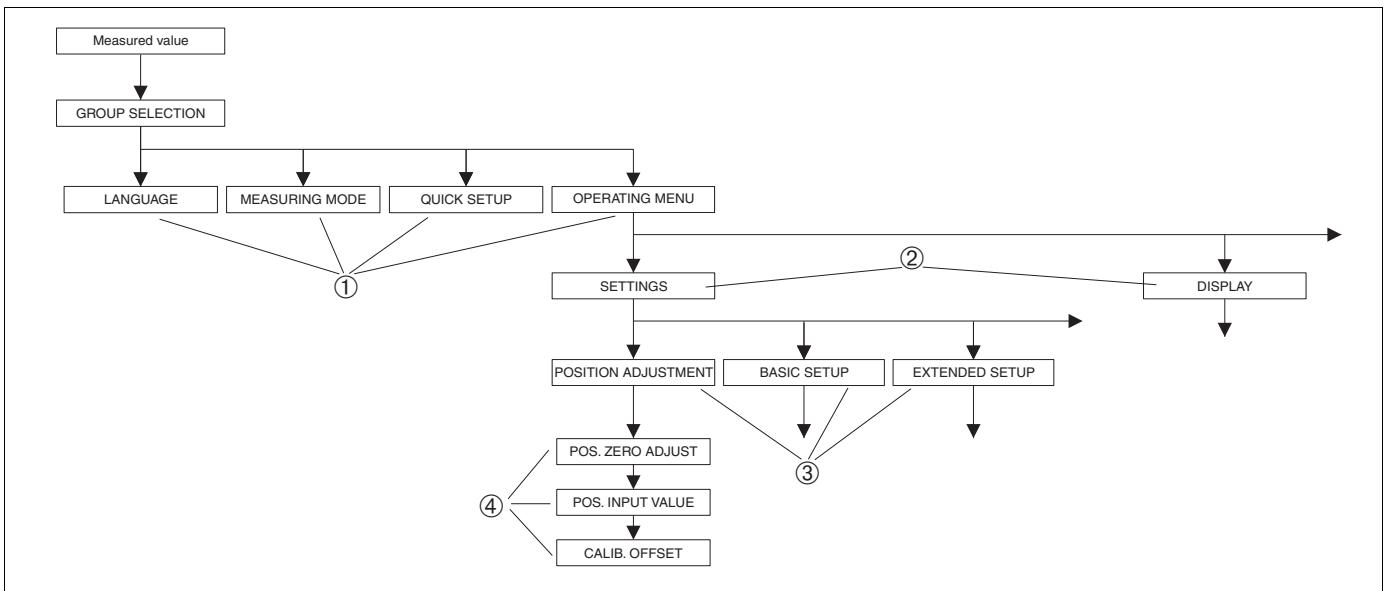

Fig. 16: Structure of the operating menu

- 1 Selection level
- 2 Selection level
- 3 Function groups
- 4 Parameter





Note!

The LANGUAGE and MEASURING MODE parameters are only displayed via the on-site display on the 1st selection level. On the HART handheld terminal, the LANGUAGE parameter

is displayed in the DISPLAY group and the MEASURING MODE parameter is displayed in the QUICK SETUP menus or in the BASIC SETUP function group. → See also section 10.1 "Operating menu for on-site display and HART handheld terminal".

5.4.2 Selecting an option

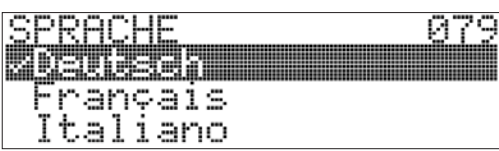
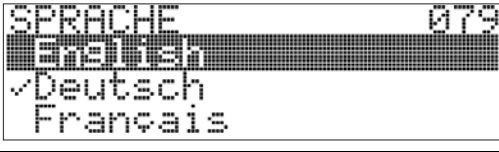
Example: select "English" as the language of the menu.

On-site display	Operation
 <p>SPRACHE 079 3 Deutsch Français Italiano</p>	<p>German is selected as the language. A 3 in front of the menu text indicates the active option.</p>
 <p>SPRACHE 079 3 English ✓ Deutsch Français</p>	<p>Select English with "+" or "-".</p>
 <p>LANGUAGE 079 3 English Deutsch Français</p>	<ol style="list-style-type: none"> 1. Confirm your choice with "E". A 3 in front of the menu text indicates the active option. (English is now selected as the menu language.) 2. Jump to the next item with "E".

5.4.3 Editing a value

Example: adjusting DAMPING VALUE function from 2.0 s to 30.0 s. → See also page 23, section 5.2.3 "Function of the operating elements".

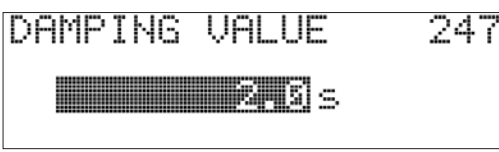
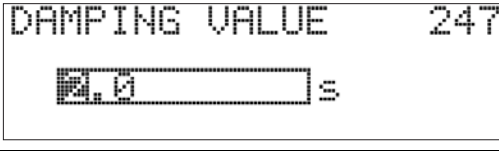
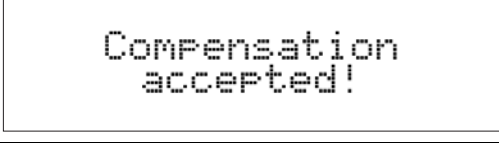
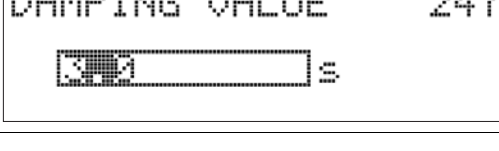
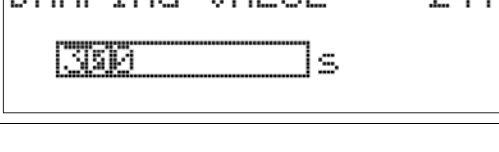
On-site display	Operation
 <p>DAMPING VALUE 247 2.0 s</p>	<p>The on-site display shows the parameter to be changed. The value highlighted in black can be changed. The "s" unit is fixed and cannot be changed.</p>
 <p>DAMPING VALUE 247 2.0 s</p>	<ol style="list-style-type: none"> 1. Press "+" or "-" to get to the editing mode. 2. The first digit is highlighted in black.
 <p>Compensation accepted!</p>	<ol style="list-style-type: none"> 1. Use "+" to change "2" to "3". 2. Confirm "3" with "E". The cursor jumps to the next position (highlighted in black).
 <p>DAMPING VALUE 247 3.0 s</p>	<p>The decimal point is highlighted in black, i.e. you can now edit it.</p>
 <p>DAMPING VALUE 247 30.0 s</p>	<ol style="list-style-type: none"> 1. Keep pressing "+" or "-" until "0" is displayed. 2. Confirm "0" with "E". The cursor jumps to the next position. ↵ is displayed and is highlighted in black. → See next graphic.

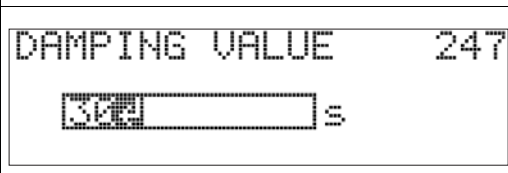
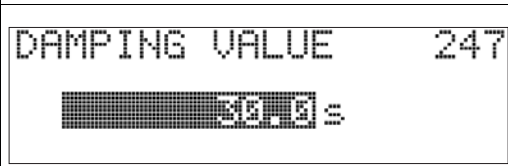
On-site display	Operation
	Use "E" to save the new value and exit the editing mode. →See next graphic.
	The new value for the damping is now 30.0 s. - Jump to the next parameter with "E". - You can get back to the editing mode with "+" or "-".

5.4.4 Taking pressure applied at device as value

Example: configuring upper range value – assign 20 mA to the pressure value 400 mbar.

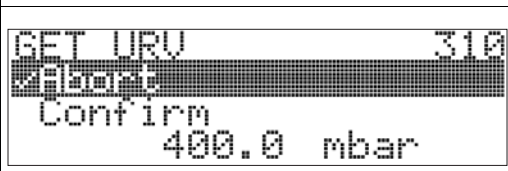
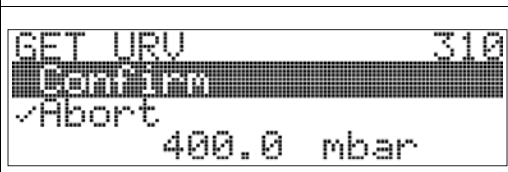
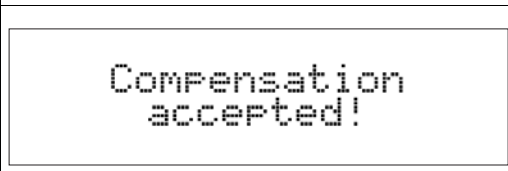
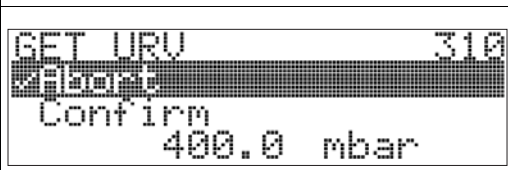
On-site display	Operation
	The bottom line on the on-site display displays the pressure present, here 400 mbar.
	Use "+" or "-" to switch to the "Confirm" option. The active selection is highlighted in black.
	Use "E" to assign the value (400 mbar) to the GET URV parameter. The device confirms the calibration and jumps back to the parameter, here GET URV (see next graphic).
	Switch to the next parameter with "E".

5.5 Operation via HART handheld terminal

Use the HART handheld terminal to set all parameters all the way along the 4...20 mA cable via menu operation.

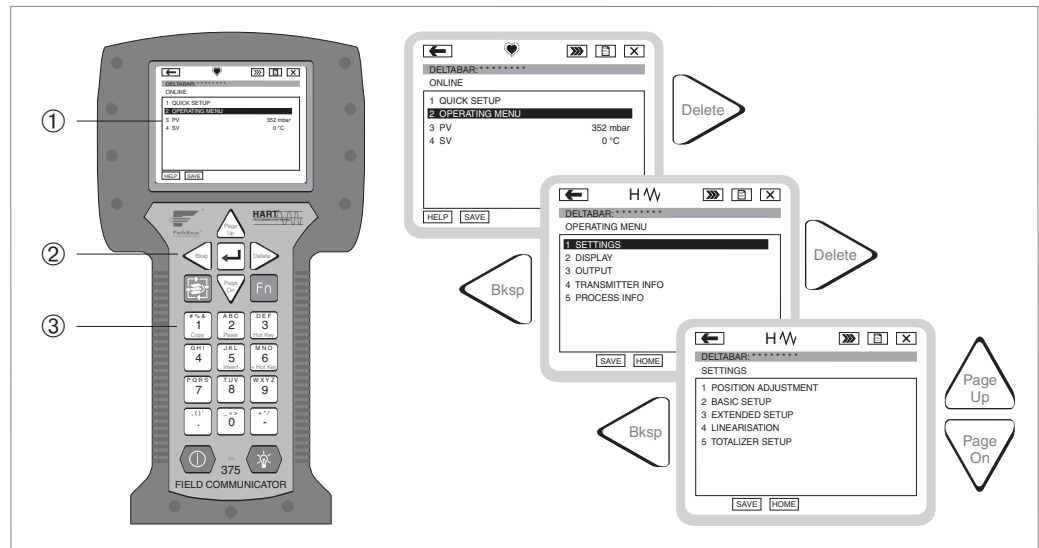

Fig. 17: HART handheld terminal, here e.g. Field Communicator DXR375 and menu guidance

- 1 LC display with menu text
- 2 Keys for menu selection
- 3 Keys for parameter entry



Note!

- → See also page 17, section 4.2.5 "Connecting HART handheld terminal".
- For further information, please refer to the Operating Instructions for the handheld terminal. The Operating Instructions are supplied with the handheld terminal.

5.6 Commuwin II operating program

Commuwin II is a graphically supported operating program for intelligent measuring devices with the HART and PROFIBUS PA communication protocols. The following operating systems are supported: Win3.1/3.11, Win95, Win98, WinNT4.0 and Win2000. Commuwin II shows the most important parameters (→ see also section 10.2 "Operating matrix HART Commuwin II).

Commuwin II supports the following functions:

- Configuration of measuring devices in on-line operation via matrix operation
- Loading and saving device data (upload/download)
- Visualisation of measured and limit values
- Presentation and recording of measured values with a line recorder.



Note!

- For further information, please refer to the Operating Instructions "Commuwin II FXS113".
- You can obtain the current device description (DD) either from your local PMA GmbH Sales Office or on request via e-mail (mailbox@pma-online.de).

5.7 Locking/unlocking operation

Once you have entered all the parameters, you can lock your entries against unauthorised and undesired access.

You have the following possibilities for locking/unlocking the operation:

- Via a DIP-switch on the electronic insert, locally on the display.
- Via the on-site display (optional)
- Via communication e.g. HART handheld terminal.

The -symbol on the on-site display indicates that operation is locked. Parameters which refer to how the display appears, e.g. LANGUAGE and DISPLAY CONTRAST can still be altered.



Note!

- If operation is locked by means of the DIP-switch, you can only unlock operation again by means of the DIP-switch. If operation is locked by means of the on-site display, you can only unlock operation again by means of the on-site display or remote operation.
- If the operation is locked, any change to the "Damping on/off" DIP switch will not have any impact on the damping time. Any change will not take effect until the operation has been unlocked again.

The table provides an overview of the locking functions:

Locking via	View/read parameter	Modify/write via ¹		Unlocking via		
		On-site display	Remote operation	DIP-switch	On-site display	Remote operation
DIP-switch	Yes	No	No	Yes	No	No
On-site display	Yes	No	No	No	Yes	Yes
Remote operation	Yes	No	No	No	Yes	Yes

1) Parameters which refer to how the display appears, e.g. LANGUAGE and DISPLAY CONTRAST can still be altered.

5.7.1 Locking/unlocking operation locally via DIP-switch

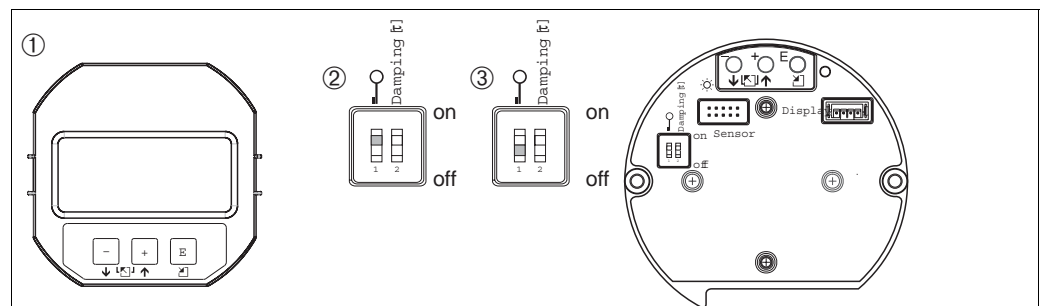

Fig. 18: DIP-switch position "Hardware locking" on the electronic insert

- 1 If necessary, remove on-site display (optional)
- 2 DIP-switch is at "on": operation is locked.
- 3 DIP-switch is at "off": operation is unlocked (operation possible)

5.7.2 Locking/unlocking operation via on-site display or remote operation

	Description
Locking operation	<ol style="list-style-type: none"> 1. Select INSERT PIN NO. parameter, Menu path: OPERATING MENU → OPERATION → INSERT PIN NO. 2. To lock operation, enter a number for this parameter between 0...9999 that is ≠100.
Unlocking operation	<ol style="list-style-type: none"> 1. Select INSERT PIN NO. parameter. 2. To unlock operation, enter "100" for the parameter.

5.8 Factory setting (reset)

By entering a certain code, you can completely, or partially, reset the entries for the parameters to the factory settings. (→ For factory settings refer to the Operating Instructions PM 50, Description of device functions". See also page 2, "Overview documentation".) Enter the code by means of the ENTER RESET CODE parameter (Menu path: (GROUP SELECTION →) OPERATING MENU → OPERATING).

There are various reset codes for the device. The following table illustrates which parameters are reset by the particular reset codes. Operation must be unlocked to reset parameters (→ see page 29, section 5.10).



Note!

Any customer-specific configuration carried out by the factory is not affected by a reset (customer-specific configuration remains). If, after a reset, you wish the parameters to be reset to the factory settings, please contact the PMA Service.

Reset code	Description and effect
1846	<p>Display reset</p> <ul style="list-style-type: none"> – This reset resets all parameters which have to do with how the display appears (DISPLAY group). – Any simulation which may be running is ended. – The device is restarted.
62	<p>PowerUp reset (warm start)</p> <ul style="list-style-type: none"> – This reset resets all the parameters in the RAM. Data are read back anew from the EEPROM (processor is initialised again). – Any simulation which may be running is ended. – The device is restarted.
2710	<p>Measuring mode level reset</p> <ul style="list-style-type: none"> – Depending on the settings for the LEVEL MODE, LIN MEASURAND, LINdMEASURAND or COMB. MEASURAND parameters, the parameters needed for this measuring task will be reset. – Any simulation which may be running is ended. – The device is restarted. <p>Example LEVEL MODE = linear and LIN. MEASURAND = Height</p> <ul style="list-style-type: none"> • HEIGHT UNIT = m • CALIBRATION MODE = wet • EMPTY CALIB. = 0 • FULL CALIB. = Sensor end value converted to mH₂O, e.g. 40.79 mH₂O for a 400 mbar sensor
333	<p>User reset</p> <ul style="list-style-type: none"> – Affects the following parameters: <ul style="list-style-type: none"> – Function group POSITION ADJUSTMENT – Function group BASIC SETUP, except for the customer-specific units – Function group EXTENDED SETUP – Group OUTPUT – Function group HART DATA: BUS ADDRESS and PREAMBLE NUMBER – Any simulation which may be running is ended. – The device is restarted.

Reset code	Description and effect
7864	Total reset <ul style="list-style-type: none">- Affects the following parameters:<ul style="list-style-type: none">- Function group POSITION ADJUSTMENT- Function group BASIC SETUP- Function group EXTENDED SETUP- Function group LINEARISATION (an existing linearisation table is erased)- Group OUTPUT- Function group PEAK HOLD INDICATOR- Function group HART DATA- All configurable messages ("Error" type) are set to "Warning".<ul style="list-style-type: none">→ See also page 38, section 8.1 "Messages" and page 44, 8.2 "Response of outputs to errors".- Function group USER LIMITS- Any simulation which may be running is ended.- The device is restarted.

6 Commissioning



Note!

The device is configured for the Pressure measuring mode as standard. The measuring range and the unit in which the measured value is transmitted correspond to the specifications on the nameplate.

6.1 Function check

Carry out a post-installation and a post-connection check as per the checklist before commissioning the device.

- "Post-installation check" checklist → see section 3.4
- "Post-connection check" checklist → see section 4.4

6.2 Selecting language and measuring mode

6.2.1 On-site operation

The LANGUAGE and MEASURING MODE parameters are located on the top menu level. → See also page, section 5.4.1 "General structure of the operating menu".

The following languages are available:

- Deutsch
- English
- Français
- Italiano
- Español
- Nederlands
- Chinese (on request)
- Japanese (on request)

The following measuring modes are available:

- Pressure
- Level

6.3 Position adjustment

Due to the orientation of the device, there may be a shift in the measured value, i.e. when the container is empty, the measured value parameter does not display zero. There are three options to choose from when performing position adjustment.

(Menu path: (GROUP SELECTION →) OPERATING MENU → SETTINGS → POSITION ADJUSTMENT)

Parameter name	Description
POS. ZERO ADJUST (685) Entry	<p>Position adjustment – the pressure difference between zero (set point) and the measured pressure need not be known. (A reference pressure is present at the device.)</p> <p>Example:</p> <ul style="list-style-type: none"> – MEASURED VALUE = 2.2 mbar – Correct the MEASURED VALUE via the POS. ZERO ADJUST parameter with the "Confirm" option. This means that you are assigning the value 0.0 to the pressure present. – MEASURED VALUE (after pos. zero adjust) = 0.0 mbar – The current value is also corrected. <p>The CALIB. OFFSET parameter displays the resulting pressure difference (offset) by which the MEASURED VALUE was corrected.</p> <p>Factory setting: 0</p>
POS. INPUT VALUE (563) Entry	<p>Position adjustment – the pressure difference between zero (set point) and the measured pressure need not be known. (A reference pressure is present at the device.)</p> <p>Example:</p> <ul style="list-style-type: none"> – MEASURED VALUE = 0.5 mbar – For the POS. INPUT VALUE parameter, specify the desired set point for the MEASURED VALUE, e.g. 2 mbar. ($\text{MEASURED VALUE}_{\text{new}} = \text{POS. INPUT VALUE}$) – MEASURED VALUE (after entry for POS. INPUT VALUE) = 2.0 mbar – The CALIB. OFFSET parameter displays the resulting pressure difference (offset) by which the MEASURED VALUE was corrected. $\text{CALIB. OFFSET} = \text{MEASURED VALUE}_{\text{old}} - \text{POS. INPUT VALUE}$, here: $\text{CALIB. OFFSET} = 0.5 \text{ mbar} - 2.0 \text{ mbar} = -1.5 \text{ mbar}$) – The current value is also corrected. <p>Factory setting: 0</p>
CALIB. OFFSET (319) Entry	<p>Position adjustment – the pressure difference between zero (set point) and the measured pressure is known. (A reference pressure is not present at the device.)</p> <p>Example:</p> <ul style="list-style-type: none"> – MEASURED VALUE = 2.2 mbar – Via the CALIB. OFFSET parameter, enter the value by which the MEASURED VALUE should be corrected. To correct the MEASURED VALUE to 0.0 mbar, you must enter the value 2.2 here. ($\text{MEASURED VALUE}_{\text{new}} = \text{MEASURED VALUE}_{\text{old}} - \text{CALIB. OFFSET}$) – MEASURED VALUE (after entry for calib. offset) = 0.0 mbar – The current value is also corrected. <p>Factory setting: 0</p>

6.4 Pressure measurement

6.4.1 Information on pressure measurement



Note!

- There is a Quick Setup menu for each of the measuring modes Pressure and Level which guides you through the most important basic functions. With the setting in the MEASURING MODE parameter, you specify which Quick Setup menu should be displayed. → See also page 32, section 6.2 "Selecting language and measuring mode".
- For pressure measurement, select the "Pressure" option by means of the MEASURING MODE parameter. The operating menu is structured appropriately. → See also section 10.1.

6.4.2 Quick Setup menu for Pressure measuring mode

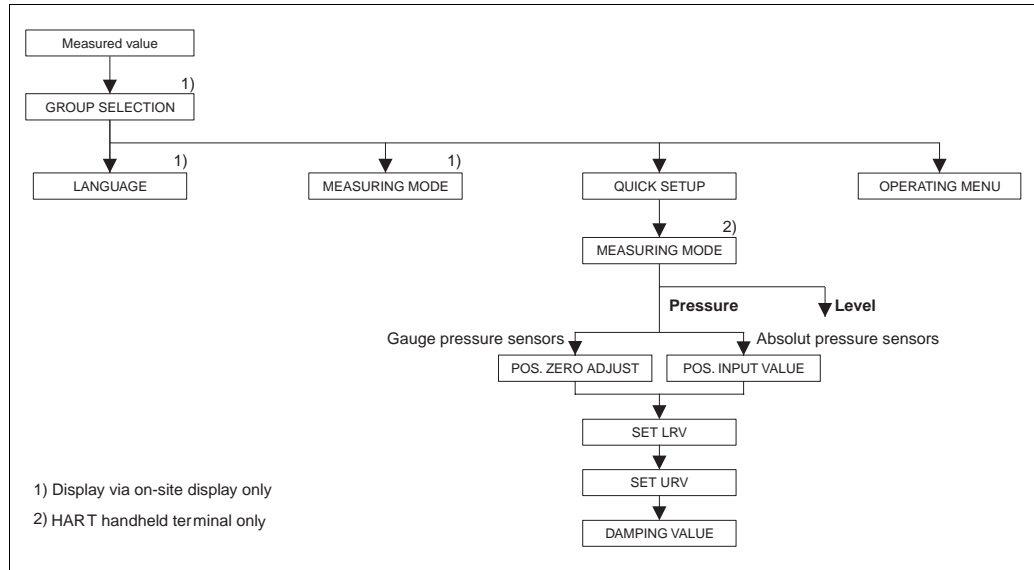

Fig. 19: Quick Setup menu for Pressure measuring mode

On-site operation
Measured value display On-site display: Switch from the measured value display to GROUP SELECTION with \square .
GROUP SELECTION Select MEASURING MODE.
MEASURING MODE Select "Pressure" option.
GROUP SELECTION Select QUICK SETUP menu.
POS. ZERO ADJUST (gauge pressure sensors) Due to orientation of the device, there may be a shift in the measured value. You correct the MEASURED VALUE via the POS. ZERO ADJUST parameter with the "Confirm" option, i. e. you assign the value 0.0 to the pressure present.
POS. ZERO ADJUST (absolute pressure sensors) Due to orientation of the device, there may be a shift in the measured value. For the POS. INPUT VALUE parameter, specify the desired set point for the MEASURED VALUE.
SET LRV Set the measuring range (enter 4 mA value). Specify a pressure value for the lower current value (4 mA value). A reference pressure does not have to be present at the device.
GET LRV Set the measuring range (enter 4 mA value). The pressure for the lower current value (4 mA value) is present at device. With the "Confirm" option, you assign the lower current value to the pressure value present.
DAMPING TIME Enter damping time (time constant τ). The damping affects the speed at which all subsequent elements, such as the on-site display, measured value and current output react to a change in the pressure.

HART handheld terminal
Measured value display Select QUICK SETUP menu.
MEASURING MODE Select "Pressure" option.
POS. ZERO ADJUST (gauge pressure sensors) Due to orientation of the device, there may be a shift in the measured value. You correct the MEASURED VALUE via the POS. ZERO ADJUST parameter with the "Confirm" option, i. e. you assign the value 0.0 to the pressure present.
POS. ZERO ADJUST (absolute pressure sensors) Due to orientation of the device, there may be a shift in the measured value. For the POS. INPUT VALUE parameter, specify the desired set point for the MEASURED VALUE.
SET LRV Set the measuring range (enter 4 mA value). Specify a pressure value for the lower current value (4 mA value). A reference pressure does not have to be present at the device.
GET LRV Set the measuring range (enter 4 mA value). The pressure for the lower current value (4 mA value) is present at device. With the "Confirm" option, you assign the lower current value to the pressure value present.
DAMPING TIME Enter damping time (time constant τ). The damping affects the speed at which all subsequent elements, such as the on-site display, measured value and current output react to a change in the pressure.



Note!

For on-site operation, see also page 23, section 5.2.3 "Function of the operating elements" and page 25, section 5.4 "On-site operation".

6.5 Level measurement

6.5.1 Information on level measurement

Three level types are available for level measurement, namely: "Linear", "Pressure Linearized" and "Height Linearized".

- Linear: select this level type if the measured variable is in direct proportion to the measured pressure. You can choose between Height, Volume, Mass or % as the measured variable.
- Pressure Linearized: select this level type if the measured variable is not in direct proportion to the measured pressure such as in the case of containers with a conical outlet. You can choose between Volume, Mass or % as the measured variable.
- Height Linearized: Select this level type if you need two measured variables or the container shape is given in value pairs such as height and volume. The following combinations are possible: "Height + Volume", "Height + Mass", "Height + %", "%-Height + Volume", "%-Height + Mass" or "%-Height + %". Perform two calibrations for this level type. First for the measured variable Height or %-Height like for the "Linear" level type and then for the measured variable Volume, Mass or % like for the "Pressure Linearized" level type.

For the level types "Linear" and "Height Linearized", the calibration modes "wet" and "dry" are available.

- Wet: wet calibration takes place by filling and emptying the container. Two pressure-level value pairs have to be entered for this calibration mode. In the case of two different levels, the level value is entered and the pressure measured at this moment is assigned to the level value.
- Dry: dry calibration is a theoretical calibration which you can carry out even if the device is not mounted or the container is empty. Depending on the measured variable selected, values for the parameters needed for the calculation are queried. For example, the density of the fluid must be entered for the "Level" measured variable.

For the "Pressure Linearized" and "Height Linearized" level type, enter a linearisation table. The entry modes "Manual" and "Semiautomatic" are available here.

- Manual: the container neither has to be filled nor emptied for this entry mode. Enter the appropriate value points for the linearisation table.
- Semiautomatic: the container is filled or emptied in stages in this entry mode. The device automatically records the hydrostatic pressure. Enter the associated volume, mass or %-value.



Note!

- There is a Quick Setup menu for each of the measuring modes Pressure and Level which guides you through the most important basic functions. With the setting in the MEASURING MODE parameter, you specify which Quick Setup menu should be displayed. → See also page 32, section 6.2 "Selecting language and measuring mode".
- For level measurement, select the "Level" option by means of the MEASURING MODE parameter. The operating menu is structured appropriately. → See also section 10.1. The factory settings for the LEVEL MODE, CALIBRATION MODE, LIN. MEASURAND, EMPTY CALIB. and FULL CALIB. parameters are as follows:
 - LEVEL MODE = Linear
 - CALIBRATION MODE = wet
 - LIN. MEASURAND = %
 - EMPTY CALIB. = 0 %
 - FULL CALIB. = 100 %.

6.5.2 Quick Setup menu for Level measuring mode



Note!

Some parameters of the "Level" measuring mode are only displayed if other parameters are appropriately configured. For example, the EMPTY PRESSURE parameter is not displayed unless the "Linear" option was selected for the LEVEL MODE parameter and the "wet" option was selected for the CALIBRATION MODE parameter (see following figure). You can find the LEVEL MODE parameter in the BASIC SETTINGS function group (menu path: (GROUP SELECTION →) OPERATING MENU → SETTINGS → BASIC SETTINGS).

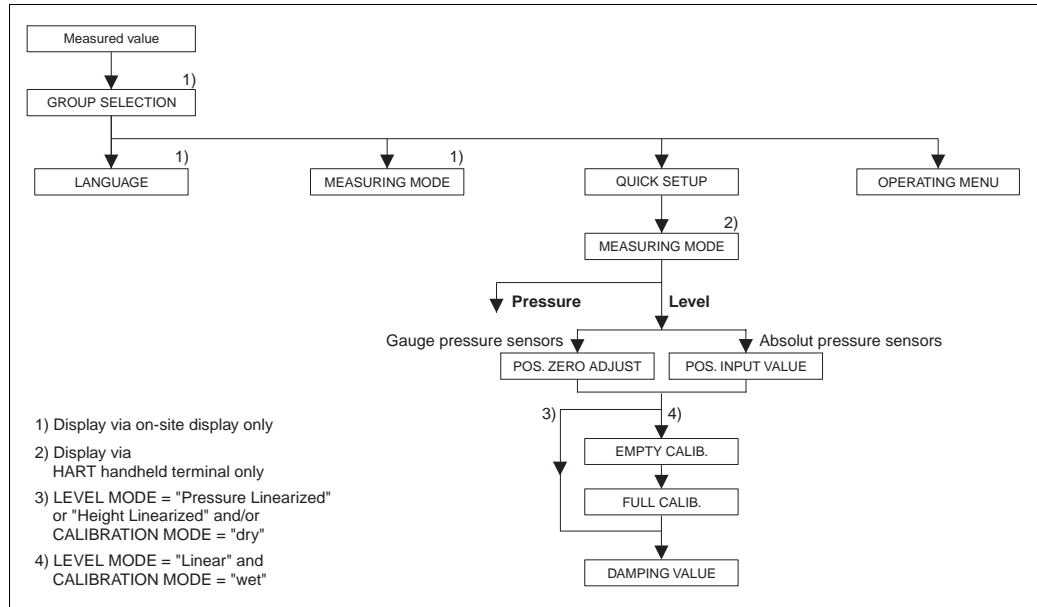

Fig. 20: Quick Setup menu for the Level measuring mode

On-site operation	HART handheld terminal
<p>Measured value display On-site display: Switch from the measured value display to GROUP SELECTION with [E].</p>	<p>Measured value display Select QUICK SETUP menu.</p>
<p>GROUP SELECTION Select MEASURING MODE.</p>	<p>MEASURING MODE Select "Level" option.</p>
<p>MEASURING MODE Select "Level" option.</p>	
<p>GROUP SELECTION Select QUICK SETUP menu.</p>	<p>POS. ZERO ADJUST (gauge pressure sensors) Due to orientation of the device, there may be a shift in the measured value. You correct the MEASURED VALUE via the POS. ZERO ADJUST parameter with the "Confirm" option, i. e. you assign the value 0.0 to the pressure present.</p>
<p>POS. ZERO ADJUST (gauge pressure sensors) Due to orientation of the device, there may be a shift in the measured value. You correct the MEASURED VALUE via the POS. ZERO ADJUST parameter with the "Confirm" option, i. e. you assign the value 0.0 to the pressure present.</p>	
<p>POS. INPUT VALUE (absolute pressure sensors) Due to orientation of the device, there may be a shift in the measured value. For the POS. INPUT VALUE parameter, specify the desired set point for the MEASURED VALUE.</p>	
	<p>POS. INPUT VALUE (absolute pressure sensors) Due to orientation of the device, there may be a shift in the measured value. For the POS. INPUT VALUE parameter, specify the desired set point for the MEASURED VALUE.</p>

On-site operation
EMPTY CALIB. (Level mode "linear", Calibration mode "wet") Enter level for the lower calibration point. For this parameter, enter a level value which is assigned to the pressure present at the device.
FULL CALIB. (Level mode "linear", Calibration mode "wet") Enter level for the upper calibration point. For this parameter, enter a level value which is assigned to the pressure present at the device.
DAMPING TIME Enter damping time (time constant τ). The damping affects the speed at which all subsequent elements, such as the on-site display, measured value and current output react to a change in the pressure.

HART handheld terminal
EMPTY CALIB. (Level mode "linear", Calibration mode "wet") Enter level for the lower calibration point. For this parameter, enter a level value which is assigned to the pressure present at the device.
FULL CALIB. (Level mode "linear", Calibration mode "wet") Enter level for the upper calibration point. For this parameter, enter a level value which is assigned to the pressure present at the device.
DAMPING TIME Enter damping time (time constant τ). The damping affects the speed at which all subsequent elements, such as the on-site display, measured value and current output react to a change in the pressure.



Note!

For on-site operation, see also page 23, section 5.2.3 "Function of the operating elements" and page 25, section 5.4 "On-site operation".

7 Maintenance

PM 50 requires no maintenance.

7.1 Exterior cleaning

Please note the following points when cleaning the device:

- The cleaning agents used should not attack the surface and the seals.
- Mechanical damage to the membrane, e.g. due to pointed objects, must be avoided.

8 Trouble-shooting

8.1 Messages

The following table lists all the possible messages that can occur.

The device differentiates between the error types "Alarm", "Warning" and "Error". At the factory, all "Error" type messages are set to "Warning".

→ See "Error type/NA 64" column and section 8.2 "Response of outputs to errors".

In addition, the "Error type/NA 64" column classifies the messages in accordance with NAMUR Recommendation NA 64:

- Break down: indicated with "B"
- Maintenance need: indicated with "C" (check request)
- Function check: indicated with "I" (in service)

Error message display on the on-site display:

- The measured value display shows the message with the highest priority. → See "Priority" column.
- The ALARM STATUS parameter shows all the messages present in descending order of priority. You can scroll through all the messages present with the -key or -key.

Message display via Commuwin II and HART handheld terminal:

- The ALARM STATUS parameter shows the message with the highest priority. → See "Priority" column.



Note!

- For support and further information, please contact the PMA Service.
- → See also section 8.4, 8.5 and 8.6.

Code	Error type/ NA 64	Message/description	Cause	Measure	Priority
101 (A101)	Alarm B	B>Sensor electronic EEPROM error	<ul style="list-style-type: none"> - Electromagnetic effects are greater than specifications in the technical data. (→ See section 9.) This message normally only appears briefly. - Sensor defect. 	<ul style="list-style-type: none"> - Wait a few minutes. - Restart the device. Perform reset (Code 62). - Block off electromagnetic effects or eliminate source of disturbance. - Replace sensor. 	17
102 (W102)	Warning C	C>Checksum error in EEPROM: peakhold segment	<ul style="list-style-type: none"> - Main electronics defect. Correct measurement can continue as long as you do not need the peak hold indicator function. 	<ul style="list-style-type: none"> - Replace main electronics. 	53
106 (W106)	Warning C	C>Downloading - please wait	<ul style="list-style-type: none"> - Downloading. 	<ul style="list-style-type: none"> - Wait for download to complete. 	52
110 (A110)	Alarm B	B>Checksum error in EEPROM: configuration segment	<ul style="list-style-type: none"> - The supply voltage is disconnected when writing. - Electromagnetic effects are greater than specifications in the technical data. (→ See section 9.) - Main electronics defect. 	<ul style="list-style-type: none"> - Reestablish supply voltage. Perform reset (Code 7864) if necessary. Carry out calibration again. - Block off electromagnetic effects or eliminate sources of disturbance. - Replace main electronics. 	6
113 (A113)	Alarm B	B>ROM failure in transmitter electronic	<ul style="list-style-type: none"> - Main electronics defect. 	<ul style="list-style-type: none"> - Replace main electronics. 	1
115 (E115)	Error C	C>Sensor overpressure	<ul style="list-style-type: none"> - Overpressure present. - Sensor defect. 	<ul style="list-style-type: none"> - Reduce pressure until message disappears. - Replace sensor. 	29
116 (W116)	Warning C	C>Download error, repeat download	<ul style="list-style-type: none"> - The file is defect. - During the download, the data are not correctly transmitted to the processor, e.g. because of open cable connections, spikes (ripple) on the supply voltage or electromagnetic effects. 	<ul style="list-style-type: none"> - Use another file. - Check cable connection PC – transmitter. - Block off electromagnetic effects or eliminate sources of disturbance. - Perform reset (Code 7864) and carry out calibration again. - Repeat download. 	36
120 (E120)	Error C	C>Sensor low pressure	<ul style="list-style-type: none"> - Pressure too low. - Sensor defect. 	<ul style="list-style-type: none"> - Increase pressure until message disappears. - Replace sensor. 	30
121 (A121)	Alarm B	B>Checksum error in factory segment of EEPROM	<ul style="list-style-type: none"> - Main electronics defect. 	<ul style="list-style-type: none"> - Replace main electronics. 	5
122 (A122)	Alarm B	B>Sensor not connected	<ul style="list-style-type: none"> - Cable connection sensor –main electronics disconnected. - Electromagnetic effects are greater than specifications in the technical data. (→ See section 9.) - Main electronics defect. - Sensor defect. 	<ul style="list-style-type: none"> - Check cable connection and repair if necessary. - Block off electromagnetic effects or eliminate source of disturbance. - Replace main electronics. - Replace sensor. 	13
130 (A130)	Alarm B	B>EEPROM is defect.	<ul style="list-style-type: none"> - Main electronics defect. 	<ul style="list-style-type: none"> - Replace main electronics. 	10
131 (A131)	Alarm B	B>Checksum error in EEPROM: min/max segment	<ul style="list-style-type: none"> - Main electronics defect. 	<ul style="list-style-type: none"> - Replace main electronics. 	9
132 (A132)	Alarm B	B>Checksum error in totalizer EEPROM	<ul style="list-style-type: none"> - Main electronics defect. 	<ul style="list-style-type: none"> - Replace main electronics. 	7

Code	Error type/ NA 64	Message/description	Cause	Measure	Priority
133 (A133)	Alarm B	B>Checksum error in History EEPROM	<ul style="list-style-type: none"> - An error occurred when writing. - Main electronics defect. 	<ul style="list-style-type: none"> - Perform reset (Code 7864) and carry out calibration again. - Replace electronics. 	8
602 (W602)	Warning C	C>Linearisation curve not monoton	<ul style="list-style-type: none"> - The linearisation table is not monotonic increasing. 	<ul style="list-style-type: none"> - Add to linearisation table or perform linearisation again. 	57
604 (W604)	Warning C	C>Linearisation table not valid. At least 2 points	<ul style="list-style-type: none"> - The linearisation table consists of less than 2 points. 	<ul style="list-style-type: none"> - Add to linearisation table. If necessary, perform linearisation again. 	58
613 (W613)	Warning I	I>Simulation is active	<ul style="list-style-type: none"> - Simulation is switched on, i.e. the device is not measuring at present. 	<ul style="list-style-type: none"> - Switch off simulation. 	60
620 (E620)	Error C	C>Current output out of range	<ul style="list-style-type: none"> The current is outside the permitted range 3.8...20.5 mA. - The pressure applied is outside the set measuring range (but within the sensor range). 	<ul style="list-style-type: none"> - Check pressure applied, reconfigure measuring range if necessary. - Perform reset (Code 7864) and carry out calibration again. 	49
700 (W700)	Warning C	C>Last configuration not stored	<ul style="list-style-type: none"> - An error occurred when writing or reading configuration data or the power supply was disconnected. - Main electronics defect. 	<ul style="list-style-type: none"> - Perform reset (Code 7864) and carry out calibration again. - Replace main electronics. 	54
701 (W701)	Warning C	C>Measuring chain config. exceeds sensor range	<ul style="list-style-type: none"> - The calibration carried out would result in the sensor nominal operating range being undershot or overshot. 	<ul style="list-style-type: none"> - Carry out calibration again. 	50
703 (A703)	Alarm B	B>Measurement error	<ul style="list-style-type: none"> - Fault in the main electronics. - Main electronics defect. 	<ul style="list-style-type: none"> - Briefly disconnect device from the power supply. - Replace main electronics. 	22
704 (A704)	Alarm B	B>Measurement error	<ul style="list-style-type: none"> - Fault in the main electronics. - Main electronics defect. 	<ul style="list-style-type: none"> - Briefly disconnect device from the power supply. - Replace main electronics. 	12
705 (A705)	Alarm B	B>Measurement error	<ul style="list-style-type: none"> - Fault in the main electronics. - Main electronics defect. 	<ul style="list-style-type: none"> - Briefly disconnect device from the power supply. - Replace main electronics. 	21
707 (A707)	Alarm B	B>X-VAL. of lin. table out of edit limits.	<ul style="list-style-type: none"> - At least one X-VALUE in the linearisation table is either below the value for HYDR. PRESS MIN. or MIN. LEVEL or above the value for HYDR. PRESS. MAX. or LEVEL MAX. 	<ul style="list-style-type: none"> - Carry out calibration again. 	38
710 (W710)	Warning C	B>Set span too small. Not allowed.	<ul style="list-style-type: none"> - Values for calibration (e.g. lower range value and upper range value) are too close together. - The sensor was replaced and the customer-specific configuration does not suit the sensor. - Unsuitable download carried out. 	<ul style="list-style-type: none"> - Adjust calibration to suit sensor. - Adjust calibration to suit sensor. - Replace sensor with a suitable sensor. - Check configuration and perform download again. 	51



Code	Error type/ NA 64	Message/description	Cause	Measure	Priority
711 (A711)	Alarm B	B>LRV or URV out of edit limits	<ul style="list-style-type: none"> – Lower range value and/or upper range value undershoot or overshoot the sensor range limits. – The sensor was replaced and the customer-specific configuration does not suit the sensor. – Unsuitable download carried out. 	<ul style="list-style-type: none"> – Reconfigure lower range value and/or upper range value to suit the sensor. Pay attention to position factor. – Reconfigure lower range value and/or upper range value to suit the sensor. Pay attention to position factor. – Replace sensor with a suitable sensor. – Check configuration and perform download again. 	37
713 (A713)	Alarm B	B>100% POINT level out of edit limits	<ul style="list-style-type: none"> – The sensor was replaced. 	<ul style="list-style-type: none"> – Carry out calibration again. 	39
715 (E715)	Error C	C>Sensor over temperature	<ul style="list-style-type: none"> – The temperature measured in the sensor is greater than the upper nominal temperature of the sensor. – Unsuitable download carried out. 	<ul style="list-style-type: none"> – Reduce process temperature/ ambient temperature. – Check configuration and perform download again. 	32
716 (A716)	Alarm B	B>Sensor diaphragm broken	<ul style="list-style-type: none"> – Sensor defect. 	<ul style="list-style-type: none"> – Replace sensor. 	24
717 (E717)	Error C	C>Transmitter over temperature	<ul style="list-style-type: none"> – The temperature measured in the electronics is greater than the upper nominal temperature of the electronics (+88 °C). – Unsuitable download carried out. 	<ul style="list-style-type: none"> – Reduce ambient temperature. – Check configuration and perform download again. 	34
718 (E718)	Error C	C>Transmitter under temperature	<ul style="list-style-type: none"> – The temperature measured in the electronics is smaller than the lower nominal temperature of the electronics (–43 °C). – Unsuitable download carried out. 	<ul style="list-style-type: none"> – Increase ambient temperature. Insulate device if necessary. – Check configuration and perform download again. 	35
719 (A719)	Alarm B	B>Y-VAL of lin. table out of edit limits	<ul style="list-style-type: none"> – At least on Y-VALUE in the linearisation table is below the MIN. TANK CONTENT or above the MAX. TANK CONTENT. 	<ul style="list-style-type: none"> – Carry out calibration again. 	40
720 (E720)	Error C	C>Sensor under temperature	<ul style="list-style-type: none"> – The temperature measured in the sensor is smaller than the lower nominal temperature of the sensor. (→ See also Operating Instructions BA274P, parameter description Tmin SENSOR or Operating Instructions, page 2.) – Unsuitable download carried out. 	<ul style="list-style-type: none"> – Increase process temperature/ ambient temperature. – Check configuration and perform download again. 	33
721 (A721)	Alarm B	B>ZERO POSITION level out of edit limits	<ul style="list-style-type: none"> – LEVEL MIN or LEVEL MAX has been changed. 	<ul style="list-style-type: none"> – Perform reset (Code 2710) and carry out calibration again. 	41
722 (A722)	Alarm B	B>EMPTY CALIB. or FULL CALIB. out of edit limits	<ul style="list-style-type: none"> – LEVEL MIN or LEVEL MAX has been changed. 	<ul style="list-style-type: none"> – Perform reset (Code 2710) and carry out calibration again. 	42
723 (A723)	Alarm B	B>MAX. FLOW out of edit limits	<ul style="list-style-type: none"> – FLOW-MEAS. TYPE has been changed. 	<ul style="list-style-type: none"> – Carry out calibration again. 	43

Code	Error type/ NA 64	Message/description	Cause	Measure	Priority
725 (A725)	Alarm B	B>Sensor connection error, cycle disturbance	<ul style="list-style-type: none"> - Electromagnetic effects are greater than specifications in the technical data. (→ See section 9.) - Sensor or main electronics defect. 	<ul style="list-style-type: none"> - Block off electromagnetic effects or eliminate source of disturbance. - Replace sensor or main electronics. 	25
726 (E726)	Error C	C>Sensor temperature error - overrange	<ul style="list-style-type: none"> - Electromagnetic effects are greater than specifications in the technical data. (→ See section 9.) - Process temperature is outside permitted range. - Sensor defect. 	<ul style="list-style-type: none"> - Block off electromagnetic effects or eliminate source of disturbance. - Check temperature present, reduce or increase if necessary. - If the process temperature is within the permitted range, replace sensor. 	31
727 (E727)	Error C	C>Sensor pressure error - overrange	<ul style="list-style-type: none"> - Electromagnetic effects are greater than specifications in the technical data. (→ See section 9.) - Pressure is outside permitted range. - Sensor defect. 	<ul style="list-style-type: none"> - Block off electromagnetic effects or eliminate source of disturbance. - Check pressure present, reduce or increase if necessary. - If the pressure is within the permitted range, replace sensor. 	28
728 (A728)	Alarm B	B>RAM error	<ul style="list-style-type: none"> - Fault in the main electronics. - Main electronics defect. 	<ul style="list-style-type: none"> - Briefly disconnect device from the power supply. - Replace main electronics. 	2
729 (A729)	Alarm B	B>RAM error	<ul style="list-style-type: none"> - Fault in the main electronics. - Main electronics defect. 	<ul style="list-style-type: none"> - Briefly disconnect device from the power supply. - Replace main electronics. 	3
730 (E730)	Error C	C>LRV user limits exceeded	<ul style="list-style-type: none"> - Pressure measured value has undershot the value specified for the Pmin ALARM WINDOW parameter. 	<ul style="list-style-type: none"> - Check system/pressure measured value. - Change value for Pmin ALARM WINDOW if necessary. 	46
731 (E731)	Error C	C>URV user limits exceeded	<ul style="list-style-type: none"> - Pressure measured value has overshoot the value specified for the Pmax ALARM WINDOW parameter. 	<ul style="list-style-type: none"> - Check system/pressure measured value. - Change value for Pmax ALARM WINDOW if necessary. 	45
732 (E732)	Error C	C>LRV Temp. User limits exceeded	<ul style="list-style-type: none"> - Temperature measured value has undershot the value specified for the Tmin ALARM WINDOW parameter. 	<ul style="list-style-type: none"> - Check system/temperature measured value. - Change value for Tmin ALARM WINDOW if necessary. 	48
733 (E733)	Error C	C>URV Temp. User limits exceeded	<ul style="list-style-type: none"> - Temperature measured value has overshoot the value specified for the Tmax ALARM WINDOW parameter. 	<ul style="list-style-type: none"> - Check system/temperature measured value. - Change value for Tmax ALARM WINDOW if necessary. 	47
736 (A736)	Alarm B	B>RAM error	<ul style="list-style-type: none"> - Fault in the main electronics. - Main electronics defect. 	<ul style="list-style-type: none"> - Briefly disconnect device from the power supply. - Replace main electronics. 	4
737 (A737)	Alarm B	B>Measurement error	<ul style="list-style-type: none"> - Fault in the main electronics. - Main electronics defect. 	<ul style="list-style-type: none"> - Briefly disconnect device from the power supply. - Replace main electronics. 	20
738 (A738)	Alarm B	B>Measurement error	<ul style="list-style-type: none"> - Fault in the main electronics. - Main electronics defect. 	<ul style="list-style-type: none"> - Briefly disconnect device from the power supply. - Replace main electronics. 	19

Code	Error type/ NA 64	Message/description	Cause	Measure	Priority
739 (A739)	Alarm B	B>Measurement error	<ul style="list-style-type: none"> - Fault in the main electronics. - Main electronics defect. 	<ul style="list-style-type: none"> - Briefly disconnect device from the power supply. - Replace main electronics. 	23
740 (E740)	Error C	C>Calculation overflow, bad configuration	<ul style="list-style-type: none"> - Level measuring mode: the measured pressure has undershot the value for HYDR. PRESS. MIN. or overshot the value for HYDR. PRESS MAX. - Flow measuring mode: the measured pressure has undershot the value for MAX. PRESS FLOW. 	<ul style="list-style-type: none"> - Check configuration and carry out calibration again if necessary. - Select a device with a suitable measuring range. - Check configuration and carry out calibration again if necessary. - Select a device with a suitable measuring range. 	27
741 (A741)	Alarm B	B>TANK HEIGHT out of edit limits	<ul style="list-style-type: none"> - LEVEL MIN or LEVEL MAX has been changed. 	<ul style="list-style-type: none"> - Perform reset (Code 2710) and carry out calibration again. 	44
742 (A742)	Alarm B	B>Sensor connection error (upload)	<ul style="list-style-type: none"> - Electromagnetic effects are greater than specifications in the technical data. (→ See section 9.) This message normally only appears briefly. - Cable connection sensor –main electronics disconnected. - Sensor defect. 	<ul style="list-style-type: none"> - Wait a few minutes. - Perform reset (Code 7864) and carry out calibration again. - Check cable connection and repair if necessary. - Replace sensor. 	18
743 (E743)	Alarm B	B>Electronic PCB error during initialisation	<ul style="list-style-type: none"> - This message normally only appears briefly. - Main electronics defect. 	<ul style="list-style-type: none"> - Wait a few minutes. - Restart the device. Perform reset (Code 62). - Replace main electronics. 	14
744 (A744)	Alarm B	B>Main electronic PCB error	<ul style="list-style-type: none"> - Electromagnetic effects are greater than specifications in the technical data. (→ See section 9.) - Main electronics defect. 	<ul style="list-style-type: none"> - Restart the device. Perform reset (Code 62). - Block off electromagnetic effects or eliminate source of disturbance. - Replace main electronics. 	11
745 (W745)	Warning C	C>Sensor data unknown	<ul style="list-style-type: none"> - Sensor does not suit the device (electronic sensor nameplate). Device continues measuring. 	<ul style="list-style-type: none"> - Replace sensor with a suitable sensor. 	56
746 (W746)	Warning C	C>Sensor connection error - initialising	<ul style="list-style-type: none"> - Electromagnetic effects are greater than specifications in the technical data. (→ See section 9.) This message normally only appears briefly. - Overpressure or low pressure present. 	<ul style="list-style-type: none"> - Wait a few minutes. - Restart the device. Perform reset (Code 7864). - Block off electromagnetic effects or eliminate source of disturbance. - Reduce or increase pressure. 	26
747 (A747)	Alarm B	B>Sensor software not compatible to electronics	<ul style="list-style-type: none"> - Sensor does not suit the device (electronic sensor nameplate). 	<ul style="list-style-type: none"> - Replace sensor with a suitable sensor. 	16
748 (A748)	Alarm B	B>Memory failure in signal processor	<ul style="list-style-type: none"> - Electromagnetic effects are greater than specifications in the technical data. (→See section 9.) - Main electronics defect. 	<ul style="list-style-type: none"> - Block off electromagnetic effects or eliminate source of disturbance. - Replace main electronics. 	15

8.2 Response of outputs to errors

The device differentiates between the error types Alarm, Warning and Error.
 → See the following table and page 38, section 8.1 "Messages".

Output	A (Alarm)	W (Warning)	E (Error: Alarm/Warning)
Current output	Assumes the value specified via the OUTPUT FAIL MODE ¹ , ALT. CURR. OUTPUT ¹ and SET MAX. ALARM ¹ parameter. → See also the following section "Configuring current output for an alarm".	Device continues measuring.	For this error, you can enter whether the device should react as in the event of an alarm or as in the event of a warning. See corresponding "Alarm" or "Warning" column.
Bar graph (on-site display)	→ See this table, current output.	→ See this table, current output.	→ See this table, current output.
On-site display	<ul style="list-style-type: none"> The measured value and message are displayed alternately Measured value display:  -symbol is permanently displayed. Message display <ul style="list-style-type: none"> 3-digit number such as A122 and Description 	<ul style="list-style-type: none"> The measured value and message are displayed alternately Measured value display:  -symbol flashes. Message display: <ul style="list-style-type: none"> 3-digit number such as W613 and Description 	<ul style="list-style-type: none"> The measured value and message are displayed alternately Measured value display: see corresponding "Alarm" or "Warning" column Message display: <ul style="list-style-type: none"> 3-digit number such as E731 and Description
Remote operation (Commwin II or HART handheld terminal)	In the case of an alarm, the ALARM STATUS ² parameter displays a 3-digit number such as 122 for "Sensor not connected".	In the case of a warning, the ALARM STATUS ² parameter displays a 3-digit number such as 613 for "Simulation is active".	In the case of an error, the ALARM STATUS ² parameter displays a 3-digit number such as 731 for "URV user limits exceeded".

- 1) Menu path: (GROUP SELECTION →) OPERATING MENU → OUTPUT
- 2) Menu path: (GROUP SELECTION →) OPERATING MENU → MESSAGES

8.2.1 Configuring current output for an alarm

You can configure the current output for the event of an alarm by means of the OUTPUT FAIL MODE, ALT. CURR. OUTPUT and SET MAX. ALARM parameters.

In the event of an alarm, the current and the bargraph assume the value entered with the OUTPUT FAIL MODE parameter.

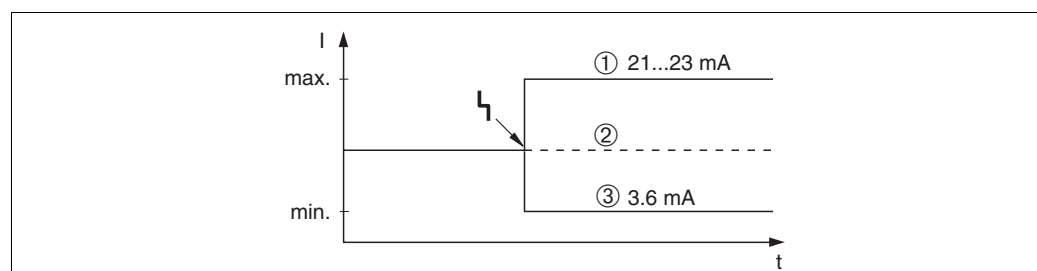

Fig. 21: Current output in the event of an alarm

Options:

- 1 Max. alarm (110%): can be set between 21...23 mA via the SET MAX. ALARM parameter
- 2 Hold meas. value: last measured value is kept
- 3 Min. alarm (-10%): 3.6 mA

Factory setting: OUTPUT FAIL MODE = max., SET MAX. ALARM = 22 mA

Use the ALT. CURR. OUTPUT parameter to set the current output value for the error messages E 120 "Sensor low pressure" and E 115 "Sensor overpressure". You have the following options:

- Normal: the current output assumes the value set via the OUTPUT FAIL MODE and SET MAX. ALARM parameters.

- NAMUR
 - Lower sensor limit undershot (E 120 "Sensor low pressure"): 3.6 mA
 - Upper sensor limit overshoot (E 115 "Sensor overpressure") overshoot: current output assumes the value set via the SET MAX ALARM parameter.

Factory setting: ALT. CURR. OUTPUT = normal



8.3 Confirming messages

Depending on the settings for the ALARM DISPL. TIME and ACK. ALARM MODE parameters, the following measures should be taken to clear a message:

Settings ¹	Measures
<ul style="list-style-type: none"> - ALARM DISPL. TIME = 0 s - ACK. ALARM MODE = off 	<ul style="list-style-type: none"> - Rectify cause of the message (see also Section 8.1).
<ul style="list-style-type: none"> - ALARM DISPL. TIME > 0 s - ACK. ALARM MODE = off 	<ul style="list-style-type: none"> - Rectify cause of the message (see also Section 8.1). - Wait for the alarm display time to elapse.
<ul style="list-style-type: none"> - ALARM DISPL. TIME = 0 s - ACK. ALARM MODE = on 	<ul style="list-style-type: none"> - Rectify cause of the message (see also Section 8.1). - Confirm message using ACK. ALARM parameter.
<ul style="list-style-type: none"> - ALARM DISPL. TIME > 0 s - ACK. ALARM MODE = on 	<ul style="list-style-type: none"> - Rectify cause of the message (see also Section 8.1). - Confirm message using ACK. ALARM parameter. - Wait for the alarm display time to elapse. If a message appears and the alarm display time elapses before the message has been acknowledged, the message will be cleared once it has been acknowledged.

1) Menu path for ALARM DISPL. TIME and ACK. ALARM MODE: (GROUP SELECTION →) OPERATING MENU → DIAGNOSTICS → MESSAGES

If the on-site display displays a message, you can delete it with the -key.

If there are several messages, the on-site display shows the message which has the highest priority (see also Section 8.1). Once you have deleted this message using the -key, the message with the next highest priority is displayed. You can use the -key to delete each message, one after the other.

The ALARM STATUS parameter continues to display all the messages present.

8.4 Repair

The PMA repairs concept provides for measuring devices to have a modular design and repairs may be carried out fast by our service.



Note!

- For certified devices, please consult Chapter "Repair of Ex-certified devices".
- For more information on service and spare parts contact the PMA Service. (→ See www.pma-online.de)

8.5 Repair of Ex-certified devices



Warning!

When repairing Ex-certified devices, please note the following:

- Only specialist personnel may undertake repairs of certified devices.
- Relevant standards, national hazardous area regulations and Safety Instructions (ATEX) and Certificates must be observed.
- Only genuine PMA GmbH spare parts may be used.
- When ordering spare parts, please check the device designation on the nameplate. Identical parts may only be used as replacements.

- Electronic inserts or sensors already in use in a standard instrument may not be used as spare parts for a certified device.
- Carry out repairs according to the instructions. After repairs, the device must fulfil the requirements of the specified individual tests.
- A certified device may only be converted into another certified variant by PMA.
- All repairs and modifications must be documented.

8.6 Returning the device

Before you send in a device for repairs or checking:

- Remove all signs of fluids, paying particular attention to seal grooves and gaps in which fluid can become lodged. This is especially important if the fluid is hazardous to health. Please refer also to the "Declaration of Contamination".

Please enclose the following when returning the device:

- Please fill out completely and sign the "Declaration of Contamination".
It is only then possible for PMA to inspect or repair the returned device.
- The chemical and physical properties of the fluid.
- A description of the application.
- A description of the error which occurred.
- Special instructions on handling, if necessary, e.g. safety data sheet as per EN 91/155/EEC.

8.7 Disposal

When disposing, separate and recycle the device components based on the materials.

9 Technical data

For technical data, please refer to the Technical Information 9498-737-51913 for PM 50.
→ See also page 2, section "Overview documentation".

10 Appendix

10.1 Operating menu for on-site display, and HART handheld terminal



Note!

- The entire menu is depicted on the following pages.
- The menu has a different structure depending on the measuring mode selected. This means that some function groups are only displayed for one measuring mode, e.g. "LINEARISATION" function group for the Level measuring mode.
- In addition, there are also parameters that are only displayed if other parameters are appropriately configured. For example the Customer Unit P parameter is only displayed if the "User unit" option was selected for the PRESS. ENG. UNIT parameter. These parameters are indicated with a "*".
- For a description of the parameters, please refer to Operating Instructions 9499-040-79811 "Description of device functions". The exact dependency of individual parameters on one another is explained here. See also page 2, section "Overview documentation".

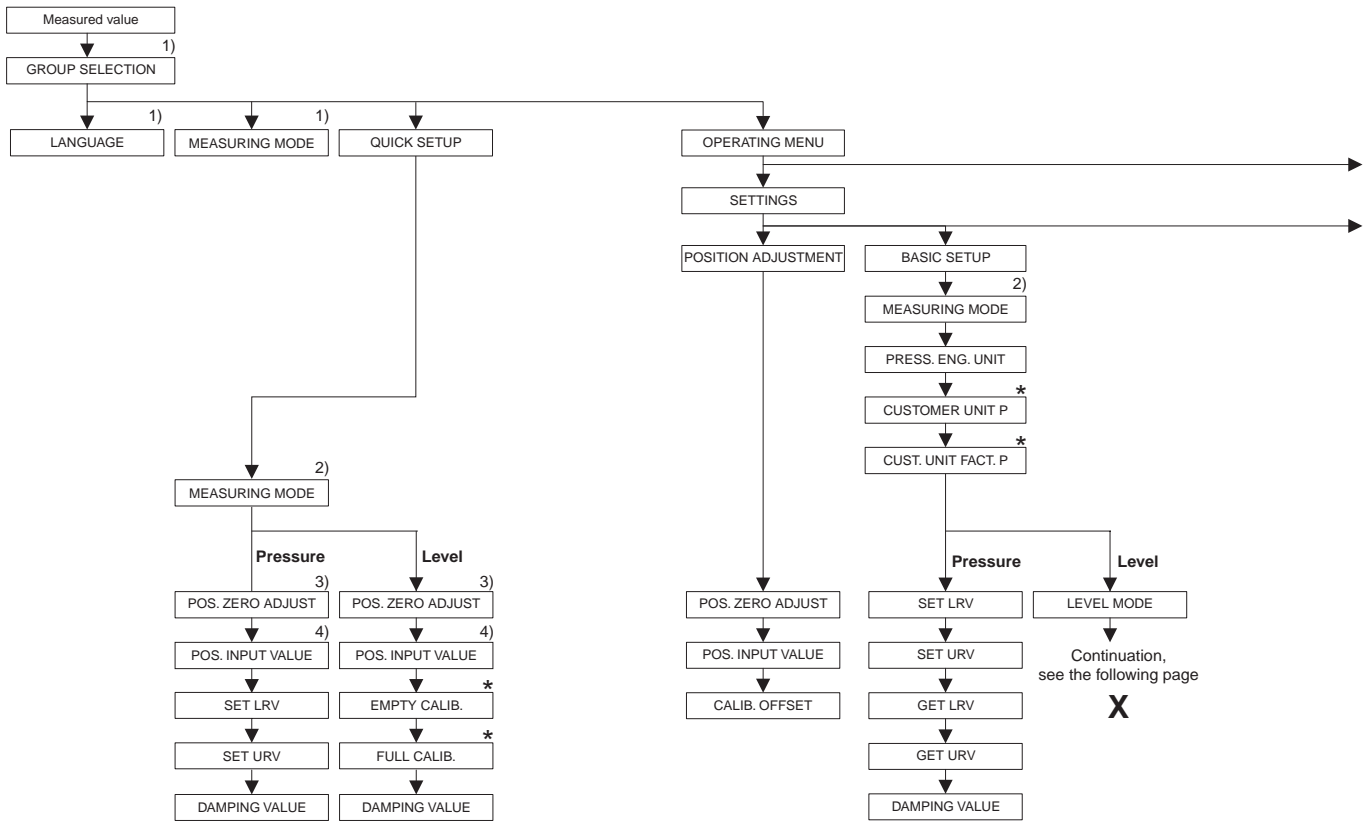

1) Display via on-site display only

2) Display via HART handheld terminal only

3) Gauge pressure sensors

4) Absolut pressure sensors

* There are parameters that are only displayed if other parameters are appropriately configured. For example the CUSTOMER UNIT P parameter is only displayed if the "User unit" option was selected for the PRESS. ENG. UNIT parameter. These parameters are indicated with a "*".

X
Continuation
BASIC SETUP "Level",
see also the previous page

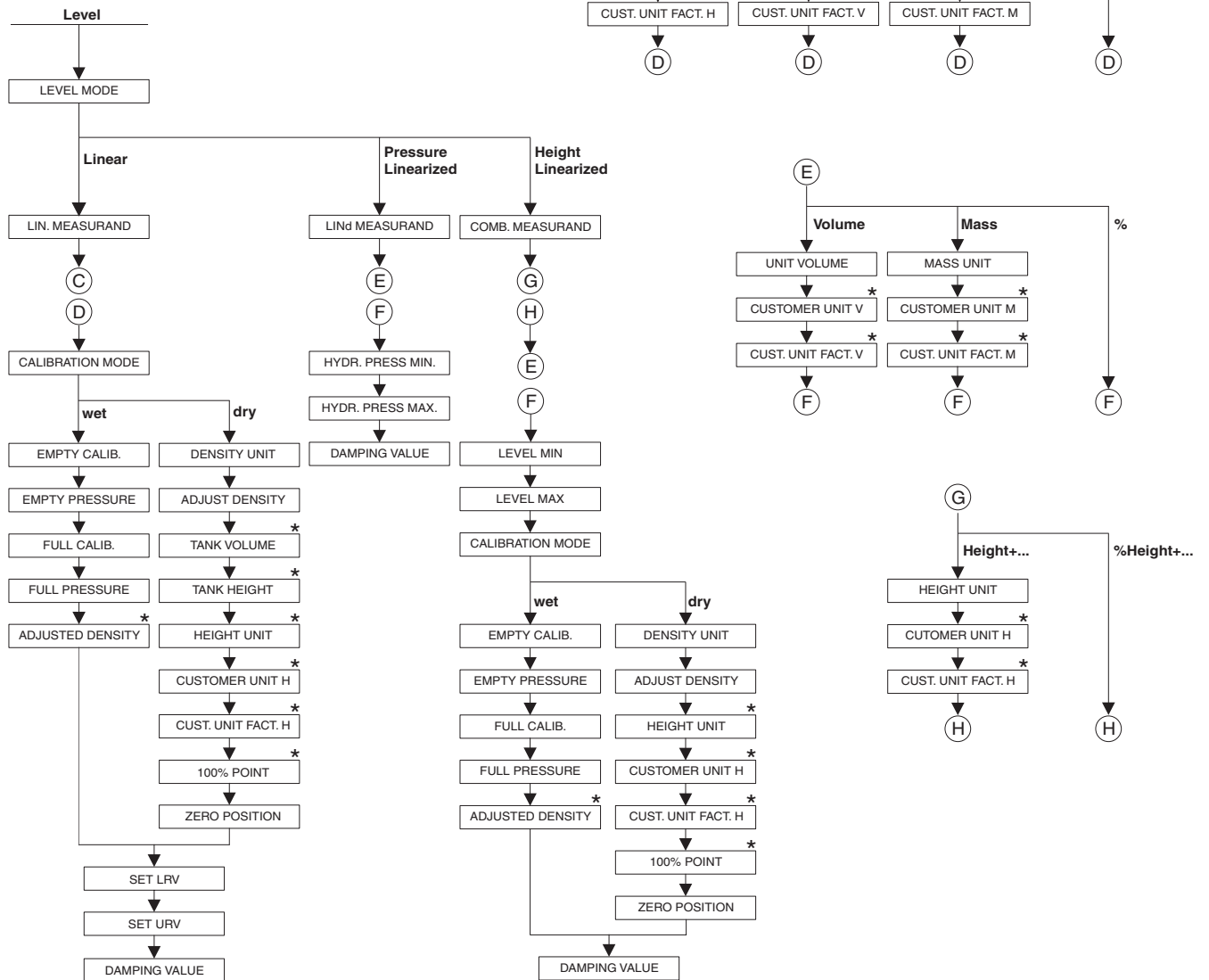

* There are parameters that are only displayed if other parameters are appropriately configured. For example the CUST. UNIT FACT. H parameter is only displayed if the "User unit" option was selected for the HEIGHT UNIT parameter. These parameters are indicated with a "*".

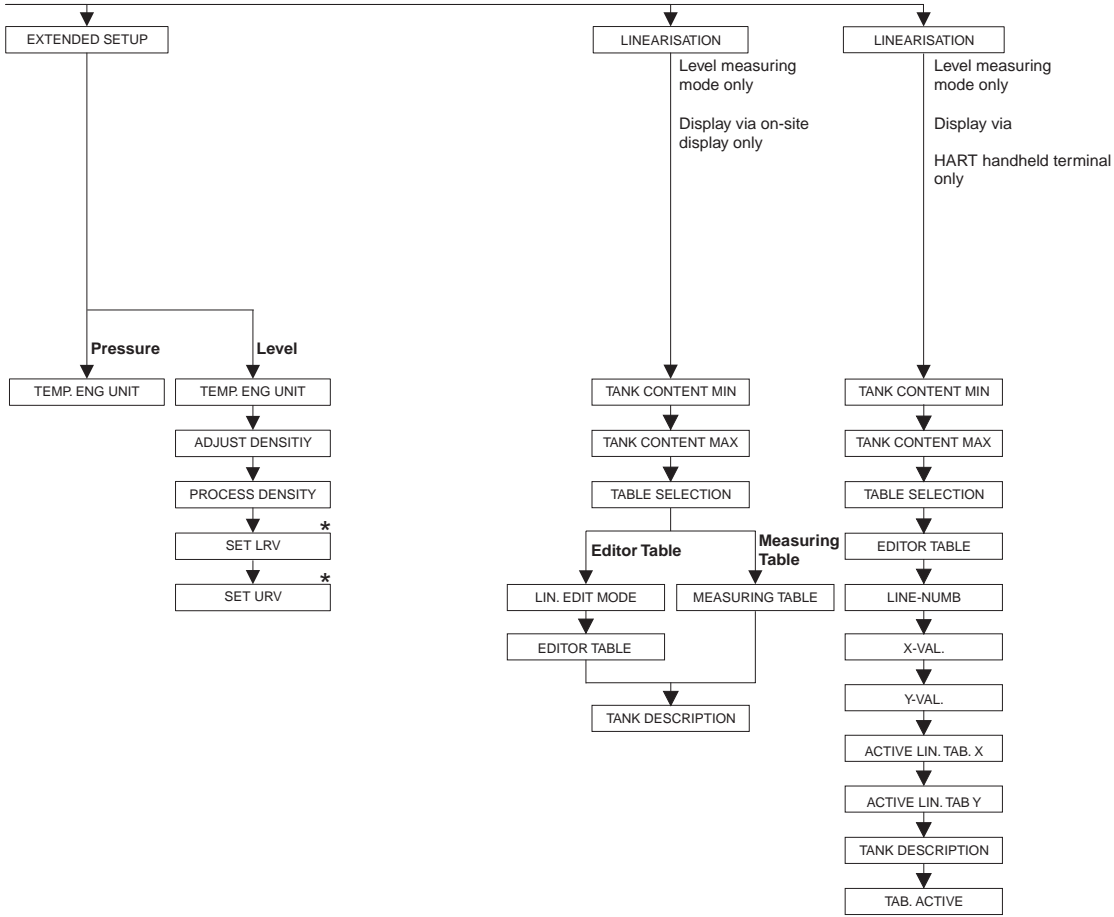

* There are parameters that are only displayed if other parameters are appropriately configured.
 These parameters are indicated with a "*".

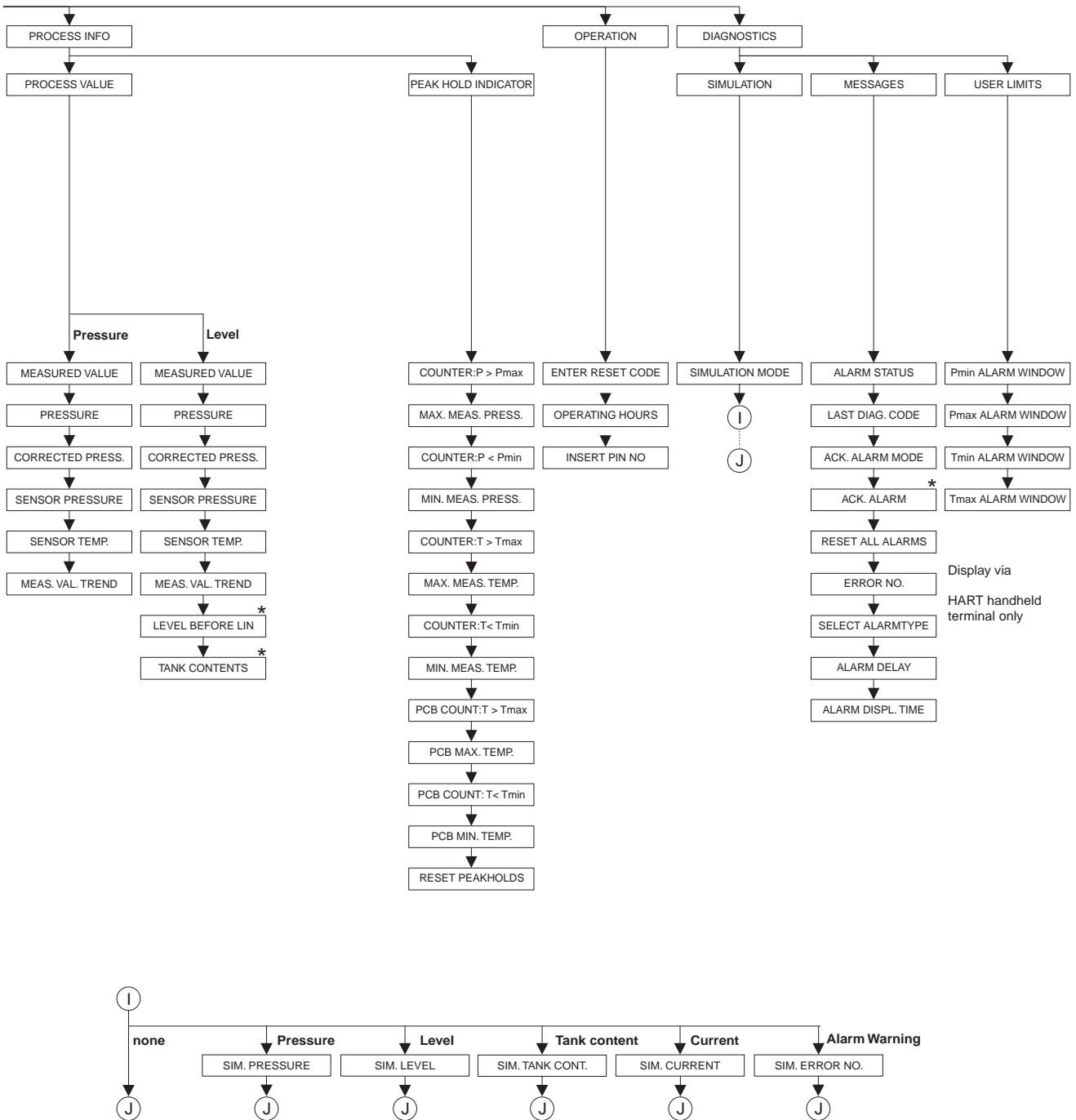

* There are parameters that are only displayed if other parameters are appropriately configured. These parameters are indicated with a "*".

10.2 Operating matrix HART Commuwin II



Note!

All parameters are displayed via the HART handheld terminal and the on-site display (→ see section 10.1). Commuwin II only displays the parameters listed below.

	H0	H1	H2	H3	H4	H5	H6	H7	H8	H9
V0 Basic setup	Measured value	Set LRV	Set URV	Get LRV	Get URV	Calib. offset	Pos. zero adjust	Damping value	Output fail mode	Press. eng. unit
V1 Peak hold indic.	Min. meas. press.	Max. meas. pressure	Pos. input value	Sensor temp.	Min. meas. temp.	Max. meas. temp.	PCB temperature	PCB min. temp.	PCB max. temp.	Temp. eng. unit
V2 Transmitter info	Counter: P < Pmin	Counter: P > Pmax	Safety lockstate		Counter: T < Tmin	Counter: T > Tmax	Reset peakhold			Table selection
V3 Linearity	Measuring mode	Level mode	Measurand	Tank content unit	Editor table	Lin. edit mode	Tab. activate	Line-numb	X-Val.	Y-Val.
V4 Level	Eng. unit level	Level min./ Hydr. press. min.	Level max./ Hydr. press. max.	Tank content min.	Tank content max.	Calibration mode	Empty calib.	Empty pressure	Full calib.	Full pressure
V5 Flow	Unit flow	Flow-meas. type	Max. pressure flow	Max flow	Low flow cut-off	Set l. fl. cut-off	Reset totalizer 1	Neg. flow tot. 1	Totalizer 1	Totalizer 1 unit
V6 Process info	Pmin Alarm window	Pmax Alarm window	Tmin Alarm window	Tmax alarm window	Proc. conn. type	Mat. proc. conn. +	Mat. proc. conn. -	Seal type	Filling fluid	Sensor meas. type
V7 Output	Output current	Set min. current	Set max. alarm	Linear/sqroot.	Assing current	Low sensor trim	High sensor trim	Press. sens. LOLIM	Press. sens. HILIM	Sensor pressure
V8 Additional function	Simulation mode	Simulated value	Main line format	Menu descriptor	Density unit	Adjust density	Zero position	100% point	DIP status	Damp switch
V9 Service	Alarm status	Last diag. code	Ack. alarm	Ack. alarm mode	Alarm delay	Alarm displ. time	Operating hours	Revision count	Enter reset code	Insert PIN no
VA User info	Cust. tag number	Additional info.	Device serial no	Sensor ser. no.	Electr. serial no	Device design.	Software version	Cust. unit flow	Flow unit scale	

10.3 Patents

This product may be protected by at least one of the following patents. Further patents are pending.

- US 5,836,063 A1 ≅ EP 0 797 084 B1
- US 5,877,424 A1 ≅ EP 0 780 674 B1
- DE 203 05 869 U1
- US 6,363,790 A1 ≅ EP 0 995 979 B1
- US 5,670,063 A1 ≅ EP 0 516 579 B1
- US 5,539,611 A1
- US 5,050,034 A1 ≅ EP 0 445 382 B1
- US 5,005,421 A1 ≅ EP 0 351 701 B1
- EP 0 414 871 B1
- EP 1 061 351 B1
- US 5,334,344 A1 ≅ EP 0 490 807 B1
- US 6,703,943 A1

Index

Numerics

4...20 mA test signal 16

A

Alarm messages 39

C

Cable specification 16

Commubox FXA 191, connection 19

D

Display 20

E

Electrical connection 14

Error messages 39

F

Factory setting 31

H

HART handheld terminal, connection 18

Hazardous areas 4

I

Incoming acceptance 8

L

Language, selection 33

Level measurement 36

Level measurement, Quick Setup menu 37

Load 17

Locking operation 30

M

Measuring arrangement for level measurement 10

Measuring arrangement for pressure measurement 9, 10

Measuring mode, selection 33

N

Nameplate 6

O

On-site display 20

Operating elements, function 22, 24

Operating elements, position 21

Operating keys, on-site, function 22, 24

Operating keys, on-site, Level measuring mode 25

Operating keys, on-site, Pressure measuring mode 24

Operating keys, position 21

Operating menu 26, 48

Overvoltage protection 19

P

Pipe mounting 12

Position adjustment 33

Potential matching 17, 19

Pressure measurement 35

Pressure measurement, Quick Setup menu	35
Q	
Quick Setup menu level	37
Quick Setup menu pressure	35
R	
Repair	47
Repair of Ex-certified devices	47
Reset	31
Rotating the housing	13
S	
Scope of delivery	7
Screening	17
SIL 2	4
Storage	8
Supply voltage	16
T	
Temperature separator, installation instructions	11
Trouble-shooting	39
U	
Unlocking operation	30
W	
Wall mounting	12
Warnings	39



Gefahrgutblatt für Reparaturen an PMA Geräten
Safety regulation form for repairs of PMA instruments
Bulletin de marchandises dangereuses pour réparations des instruments PMA

Firma / company / entreprise: _____ Abt./dept./service _____
 Anschrift / adress / adresse: _____ Name/name/nom _____
 _____ Tel./phone _____
 _____ Fax: _____
 Sensortyp / type of sensor / modèle de détecteur: _____ Seriennummer/serial no./Numéro de série _____

Fehlerbeschreibung / Description of fault in english language:

Prozessdaten / process data / données des opérations

Medium : _____ chemische Formel/chemical formula/Formule chimique _____

Aggregatzustand / state of aggregation /Etat d'agrégation

flüssig/liquid fest/solid
 liquide solide
 gasförmig/gazeous pulverig/powdery
 gazéiforme poudreux

Ex-Anlage / Ex-Zone / Ex-plan

Ja Zone
 Yes Class
 Oui
 Nein
 No
 Non

Gereinigt mit / cleaned with / nettoyé avec

"Falls spezielle Handhabungsvorschriften nötig sind, legen Sie diese bitte bei."
 "If special handling regulations required, please attach."
 "Au cas où des règles de manipulations spécifiques sont nécessaires, veuillez les joindre s. v. p."

Sicherheitshinweise / safety regulations / Normes de sécurité
 (muß angekreuzt werden / must be marked / obligation de cocher)

<input type="checkbox"/>	<input type="checkbox"/>	<input type="checkbox"/>	<input type="checkbox"/>	<input type="checkbox"/>	<input type="checkbox"/>	<input type="checkbox"/>	<input type="checkbox"/>	<input type="checkbox"/>
biologisch gefährlich biological hazardous biologiquement dangereux	radioaktiv radioactive radioactif	giftig poisonous poison	brennbar flammable combustible	brandfördernd inflammable inflammable	explosiv explosive explosif	gesundheitsschädlich harmful to health nuisible à la santé	ätzend corrosive corrosif	ungefährlich safe to handle sans danger

Hiermit bestätigen wir, dass die zurückgeschickten Geräte frei sind von jeglichen Gefahr- oder Giftstoffen (Säuren, Laugen, Lösungsmitteln usw.). Radioaktive kontaminierte Geräte müssen vor Einsendung entsprechend den Strahlenschutzvorschriften dekontaminiert werden.
 We herewith confirm that the returned instruments are free of any dangerous or toxic materials (acids, caustics, solvents, etc.). Radioactive contaminated instruments must be decontaminated according nuclear safety regulations prior to shipment.
 Par la présente, nous certifions que les instruments en retour sont exempts de tous risques de contamination ou de matières toxiques. Avant expédition les instruments contaminés par de la radio-activité doivent être décontaminés en référence aux prescriptions des règles de sécurité en vigueur contre les radiations nucléaires.

Datum : _____ Unterschrift : _____
 Date : _____ Signature : _____

Lieber Kunde, bitte helfen Sie uns mit Ihren Informationen, damit wir Ihre Reparatur schnell, exakt und risikofrei durchführen können.
 Dear customer, please help us with your informations to handle your repair fast, exact and free of any risks for the technicians.
 Cher client, aidez-nous avec vos informations, afin que nous puissions exécuter vos réparations rapidement, exactement et sans risques.



71026705 BA 271O/94/en

www.pma-online.de

Bei Änderungen erfolgt keine Mitteilung.

© PMA Prozeß- und Maschinen-Automation GmbH
Postfach 310 220, D - 34058 Kassel
Printed in Germany 9499 040 79811 (0609)

A4